

# TOSHIBA

Leading Innovation >>>

## *Air to Air Heat Exchanger* **Installation Manual**

---

**Concealed microcomputer  
control type**

Model name: \_\_\_\_\_

**VN-M150HE**

**VN-M250HE**

**VN-M350HE**

**VN-M500HE**

**VN-M650HE**

**VN-M800HE**

**VN-M1000HE**

**VN-M1500HE**

**VN-M2000HE**

For commercial use

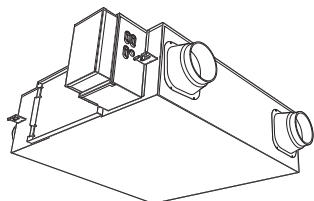

**Original instruction**

Thank you very much for purchasing TOSHIBA Air to Air Heat Exchanger.  
Please read this owner's manual carefully before using your Air to Air Heat Exchanger.

- Obtain the "Owner's manual" and "Installation manual" from constructor (or dealer).

Request to constructor or dealer

- Please clearly explain the contents of the Owner's manual and hand over it.

- Read this Installation Manual thoroughly to fully understand everything about your Toshiba Air to Air Heat Exchanger and be able to install it properly.
- Ask a qualified installer or qualified service person to perform installation.
- System parts such as a wired remote controller (sold separately) are necessary for using this unit.
- After installation, perform a test operation and confirm the safety, then explain to the customer how to use this unit. Give this installation manual to the customer and ask him / her to keep it with the owner's manual.

**■ Handover to the customer**

- Hand the owner's manual and installation manual to the customer.
- Before the handover, explain fully to the customer the contents of the owner's manual.

**Contents**

<b>1</b>	<b>Precautions for safety</b> .....	<b>2</b>
<b>2</b>	<b>Accessory parts</b> .....	<b>4</b>
<b>3</b>	<b>Cautions for installation</b> .....	<b>4</b>
<b>4</b>	<b>Separately sold parts</b> .....	<b>5</b>
<b>5</b>	<b>Reference diagram</b> .....	<b>5</b>
<b>6</b>	<b>Model list</b> .....	<b>6</b>
<b>7</b>	<b>Installation</b> .....	<b>7</b>
<b>8</b>	<b>Electric wiring</b> .....	<b>8</b>
<b>9</b>	<b>Installation method for each system configuration</b> .....	<b>11</b>
<b>10</b>	<b>Advanced system</b> .....	<b>16</b>
<b>11</b>	<b>Advanced control</b> .....	<b>19</b>
<b>12</b>	<b>Test run</b> .....	<b>23</b>
<b>13</b>	<b>Maintenance</b> .....	<b>24</b>
<b>14</b>	<b>Troubleshooting</b> .....	<b>25</b>

Please read carefully through these instructions that contain important information which complies with the "Machinery" Directive (Directive 2006/42/EC), and ensure that you understand them.

**Generic Denomination: Air to Air Heat Exchanger****Definition of Qualified Installer or Qualified Service Person**

The Air to Air Heat Exchanger must be installed, maintained, repaired and removed by a qualified installer or qualified service person. When any of these jobs is to be done, ask a qualified installer or qualified service person to do them for you. A qualified installer or qualified service person is an agent who has the qualifications and knowledge described in the table below.



Agent	Qualifications and knowledge which the agent must have
Qualified installer	<ul style="list-style-type: none"> <li>• The qualified installer is a person who installs, maintains, relocates and removes the Air to Air Heat Exchanger made by Toshiba Carrier Corporation. He or she has been trained to install, maintain, relocate and remove the Air to Air Heat Exchanger made by Toshiba Carrier Corporation or, alternatively, he or she has been instructed in such operations by an individual or individuals who have been trained and is thus thoroughly acquainted with the knowledge related to these operations.</li> <li>• The qualified installer who is allowed to do the electrical work involved in installation, relocation and removal has the qualifications pertaining to this electrical work as stipulated by the local laws and regulations, and he or she is a person who has been trained in matters relating to electrical work on the Air to Air Heat Exchanger made by Toshiba Carrier Corporation or, alternatively, he or she has been instructed in such matters by an individual or individuals who have been trained and is thus thoroughly acquainted with the knowledge related to this work.</li> <li>• The qualified installer who is allowed to work at heights has been trained in matters relating to working at heights with the Air to Air Heat Exchanger made by Toshiba Carrier Corporation or, alternatively, he or she has been instructed in such matters by an individual or individuals who have been trained and is thus thoroughly acquainted with the knowledge related to this work.</li> </ul>
Qualified service person	<ul style="list-style-type: none"> <li>• The qualified service person is a person who installs, repairs, maintains, relocates and removes the Air to Air Heat Exchanger made by Toshiba Carrier Corporation. He or she has been trained to install, repair, maintain, relocate and remove the Air to Air Heat Exchanger made by Toshiba Carrier Corporation or, alternatively, he or she has been instructed in such operations by an individual or individuals who have been trained and is thus thoroughly acquainted with the knowledge related to these operations.</li> <li>• The qualified service person who is allowed to do the electrical work involved in installation, repair, relocation and removal has the qualifications pertaining to this electrical work as stipulated by the local laws and regulations, and he or she is a person who has been trained in matters relating to electrical work on the Air to Air Heat Exchanger made by Toshiba Carrier Corporation or, alternatively, he or she has been instructed in such matters by an individual or individuals who have been trained and is thus thoroughly acquainted with the knowledge related to this work.</li> <li>• The qualified service person who is allowed to work at heights has been trained in matters relating to working at heights with the Air to Air Heat Exchanger made by Toshiba Carrier Corporation or, alternatively, he or she has been instructed in such matters by an individual or individuals who have been trained and is thus thoroughly acquainted with the knowledge related to this work.</li> </ul>

**Definition of Protective Gear**

When the Air to Air Heat Exchanger is to be transported, installed, maintained, repaired or removed, wear protective gloves and 'safety' work clothing. In addition to such normal protective gear, wear the protective gear described below when undertaking the special work detailed in the table below. Failure to wear the proper protective gear is dangerous because you will be more susceptible to injury, burns, electric shocks and other injuries.

Work undertaken	Protective gear worn
All types of work	Protective gloves 'Safety' working clothing
Electrical-related work	Gloves to provide protection for electricians and from heat
Work done at heights (50 cm or more)	Helmets for use in industry
Transportation of heavy objects	Shoes with additional protective toe cap

**Warning indications on the Air to Air Heat Exchanger**

Warning indication	Description
 <p><b>WARNING</b> <b>ELECTRICAL SHOCK HAZARD</b> Disconnect all remote electric power supplies before servicing.</p>	<p><b>WARNING</b> ELECTRICAL SHOCK HAZARD Disconnect all remote electric power supplies before servicing.</p>
 <p><b>WARNING</b> Moving parts. Do not operate unit with inspection cover removed. Stop the unit before the servicing.</p>	<p><b>WARNING</b> Moving parts. Do not operate unit with inspection cover removed. Stop the unit before the servicing.</p>
 <p><b>CAUTION</b> High temperature parts. You might get burned when removing this cover.</p>	<p><b>CAUTION</b> High temperature parts. You might get burned when removing this cover.</p>

# 1 Precautions for safety

**WARNING**

**General**

- Before starting to install the Air to Air Heat Exchanger, read carefully through the Installation Manual, and follow its instructions to install the Air to Air Heat Exchanger.
- Only a qualified installer(\*1) or qualified service person(\*1) is allowed to install the Air to Air Heat Exchanger. If the Air to Air Heat Exchanger is installed by an unqualified individual, a fire, electric shocks, injury, water leakage, noise and/or vibration may result.
- If using separately sold products, make sure to use Toshiba specified products only. Using unspecified products may cause fire, electric shock, water leak or other failure.
- Before opening the electrical control cover or inspection cover of the Air to Air Heat Exchanger, set the circuit breaker to the OFF position. Failure to set the circuit breaker to the OFF position may result in electric shocks through contact with the interior parts. Only a qualified installer(\*1) or qualified service person(\*1) is allowed to remove the electrical control cover or inspection cover of the Air to Air Heat Exchanger and do the work required.
- Before carrying out the installation, maintenance, repair or removal work, set the circuit breaker to the OFF position. Otherwise, electric shocks may result.
- Place a "Work in progress" sign near the circuit breaker while the installation, maintenance, repair or removal work is being carried out. There is a danger of electric shocks if the circuit breaker is set to ON by mistake.
- Only a qualified installer(\*1) or qualified service person(\*1) is allowed to undertake work at heights using a stand of 50 cm or more or to remove the electrical control cover or inspection cover of the Air to Air Heat Exchanger to undertake work.
- Wear protective gloves and safety work clothing during installation, servicing and removal.
- When working at heights, use a ladder which complies with the ISO 14122 standard, and follow the procedure in the ladder's instructions. Also wear a helmet for use in industry as protective gear to undertake the work.
- When cleaning the filter or heat exchange element of the Air to Air Heat Exchanger, set the circuit breaker to OFF without fail, and place a "Work in progress" sign near the circuit breaker before proceeding with the work.
- When working at heights, put a sign in place so that no-one will approach the work location, before proceeding with the work. Parts and other objects may fall from above, possibly injuring a person below.
- The Air to Air Heat Exchanger must be transported in stable condition. In case an accident such as dropping of the unit occurs while transporting the Air to Air Heat Exchanger, contact the dealer.
- Do not move or repair any unit by yourself. There is high voltage inside the unit. You may get electric shock when removing the cover and main unit.
- Do not modify the products. Do not also disassemble or modify the parts. It may cause a fire, electric shock or injury.
- Confirm whether there is a risk of the Air to Air Heat Exchanger falling down during maintenance or repairing work.
- Before opening the Supply / Exhaust air grill, set the circuit breaker to the OFF position. Otherwise, your hand may be caught in the rotating parts inside and an injury may result.

**Selection of installation location**

- Do not install the Air to Air Heat Exchanger in a location that may be subject to a risk of exposure to a combustible gas. If a combustible gas leaks and becomes concentrated around the unit, a fire may occur.
- When transporting the Air to Air Heat Exchanger, wear shoes with additional protective toe caps, protective gloves and other protective clothing.
- When transporting the Air to Air Heat Exchanger, do not take hold of the bands around the packing carton. You may injure yourself if the bands should break.
- Install the Air to Air Heat Exchanger at least 2.5 m above the floor level since otherwise the users may injure themselves or receive electric shocks if they poke their fingers or other objects into the Air to Air Heat Exchanger while it is running.
- Do not place any combustion appliance in a place where it is directly exposed to the wind of Air to Air Heat Exchanger, otherwise it may cause imperfect combustion.
- Use a hand truck or forklift to carry the unit. When carrying it by human power, have four persons or more (VN-M150 to 1000HE) eight persons or more (VN-M1500 and 2000HE); otherwise, you may strain your back.

**Installation**

- Use a winch or hoist to install Air to Air Heat Exchanger.
- When the Air to Air Heat Exchanger is to be suspended, the designated hanging bolts (M10 to M12) and nuts (M10 to M12) must be used.
- Install the Air to Air Heat Exchanger at enough strong places to withstand the weight of the unit. If the strength is not enough, the unit may fall down resulting in injury.
- Follow the instructions in the Installation Manual to install the Air to Air Heat Exchanger. Failure to follow these instructions may cause the product to fall down or topple over or give rise to noise, vibration, water leakage, etc.

**Electrical wiring**

- Only a qualified installer(\*1) or qualified service person(\*1) is allowed to carry out the electrical work of the Air to Air Heat Exchanger. Under no circumstances must this work be done by an unqualified individual since failure to carry out the work properly may result in electric shocks and/or electrical leaks.
- When repairing the electrical parts or undertaking other electrical jobs, wear gloves to provide protection for electricians and from heat. Failure to wear this protective gear may result in burn.
- Use wiring that meets the specifications in the Installation Manual and the stipulations in the local regulations and laws. Use of wiring which does not meet the specifications may give rise to electric shocks, electrical leakage, smoking and/or a fire.
- Connect earth wire. (Grounding work)  
Incomplete earthing causes an electric shock.
- Do not connect earth wires to gas pipes, water pipes, and lightning rods or earth wires for telephone wires.
- After completing the repair or relocation work, check that the earth wires are connected properly.
- Install a circuit breaker that meets the specifications in the installation manual and the stipulations in the local regulations and laws. Use an exclusive power supply circuit for the Air to Air Heat Exchanger at the rated voltage.
- Install the circuit breaker where it can be easily accessed by the agent.
- When installing the circuit breaker outdoors, install one which is designed to be used outdoors.
- Under no circumstances must the power cable be extended. Connection trouble in the places where the cable is extended may give rise to smoking and/or a fire.
- Electrical wiring work shall be conducted according to law and regulation in the community and installation manual. Failure to do so may result in electrocution or short circuit.
- When carrying out electric connection, use the wire specified in the Installation Manual and connect and fix the wires securely to prevent them applying external force to the terminals. Improper connection or fixing may result in fire.

**Test run**

- Before operating the Air to Air Heat Exchanger after having completed the work, check that the electrical control cover and inspection cover are closed, and set the circuit breaker to the ON position. You may receive an electric shock if the power is turned on without first conducting these checks.
- When there is some kind of trouble (such as when an error display has appeared, there is a smell of burning, abnormal sounds are heard, or water is leaking) has occurred in the Air to Air Heat Exchanger, do not touch the Air to Air Heat Exchanger yourself but set the circuit breaker to the OFF position, and contact a qualified service person. Take steps to ensure that the power will not be turned on (by marking "out of service" near the circuit breaker, for instance) until qualified service person arrives. Continuing to use the Air to Air Heat Exchanger in the trouble status may cause mechanical problems to escalate or result in electric shocks, etc.
- After the work has finished, use an insulation tester set (500 V Megger) to check the resistance is 1 MΩ or more between the charge section and the non-charge metal section (Earth section). If the resistance value is low, a disaster such as a leak or electric shock is caused at user's side.
- Upon completion of the installation work, check the insulation resistance. Then conduct a test run to check that the Air to Air Heat Exchanger is operating properly.

**Explanations given to user**

- Upon completion of the installation work, tell the user where the circuit breaker is located. If the user does not know where the circuit breaker is, he or she will not be able to turn it off in the event that trouble has occurred in the Air to Air Heat Exchanger.
- After the installation work, follow the Owner's Manual to explain to the customer how to use and maintain the unit.
- If there is a danger of the Air to Air Heat Exchanger falling, do not approach the Air to Air Heat Exchanger but set the circuit breaker to the OFF position, and contact a qualified service person(\*1) to have the repairs done. Do not set the circuit breaker to the ON position until the repairs are completed.

**Relocation**

- Only a qualified installer(\*1) or qualified service person(\*1) is allowed to relocate the Air to Air Heat Exchanger. It is dangerous for the Air to Air Heat Exchanger to be relocated by an unqualified individual since a fire, electric shocks, injury, water leakage, noise and/or vibration may result.

(\*1) Refer to the "Definition of Qualified Installer or Qualified Service Person."

**⚠ CAUTION****To disconnect the appliance from main power supply.**

- Means for disconnection having a contact separation in all poles at least 3 mm must be incorporated in the fixed wiring in accordance with the wiring rules.



**The installation fuse (all types can be used) must be used for the power supply line of this Air to Air Heat Exchanger.**

- The external air intake opening should be positioned away from the exhaust openings of combustion gases. The intake of such gases could cause a lack of oxygen in the room. The external air intake opening should not be positioned where discharged air may directly enter it. A situation like this will lead to the room being contaminated and this may pose a health risk.
- Netting or something similar should be provided at the external air intake opening to prevent birds or other things interfering with the unit.
- Nests or other foreign objects should be removed. That could cause a lack of oxygen in the room.
- To pierce the metal duct through the metal lath or the wire lath or the metal plate of the wooden facility, do not forget to insulate electrically between the duct and the wall. Otherwise, it would cause an electric shock or an electric leakage.
- Install the outdoor duct in a falling gradient toward the outside so as to prevent water from coming in. If it is not installed so, the building is likely to be flooded, wetting the household effects.
- Heat-insulate the outdoor duct (including the indoor side, if necessary) to prevent dewing. If heat insulation is not adequate, water likely goes indoor and wets the household properties.
- When it is high humid and high temperature inside the ceiling, a ventilation system must be installed inside the ceiling. Otherwise, it could cause a fire or an electric leakage.
- Install the power line and the connecting line with accuracy so the power source cover may not float. If the installation of the electrical control cover is inappropriate, the pin connection area is likely to cause a heat generation, a fire and an electric shock due to dust or powder.
- Do not use the unit at the other voltages than the rated one. It could cause a fire or an electric shock.
- Do not install the unit in locations with large amounts of oily smoke, such as food preparation areas. It could cause a fire.
- Do not install the unit at the place of a high temperature or a flame. It could cause a heat generation or a fire.
- Do not install in locations with high humidity, such as close to bathroom or other similar environment. It could cause an electric shock or an electric leakage or other troubles.
- Install an earth leakage breaker that is not tripped by shock waves. If an earth leakage breaker is not installed, an electric shock may be caused.
- Do not install the unit and inside air intake in a place such as a machine factory, chemical plant, or research institute, where acids, alkaline, organic solvents, or coating materials are handled and toxic gases and/or corrosive gases may be produced. Otherwise gas poisoning may occur and/or the inside of the unit may be eroded or deteriorated. The deterioration and erosion may result in an fire.
- After installation, switch off the circuit breaker for safety if the unit will not be used for a long time.
- Attach the parts such as the inspection cover securely.

**■ Disposal**

Dispose of Air to Air Heat Exchanger in accordance with the 2002/96/EC Directive WEEE (Waste Electrical and Electronic Equipment).

## 2 Accessory parts

Name	Quantity	Shape	Usage
Installation manual	1	—	(Hand it to the customers.)
CD-ROM (Owner's manual and Installation manual)	1	—	(For other languages that do not appear in this manual, please refer to the enclosed CD-ROM.)
Owner's manual	1	—	(Hand it to the customers.)
Adapter	4		Connection parts for the duct
Screw	16/24		Screws for attaching the adapter

## 3 Cautions for installation

Make the inspection opening at the specific place on the ceiling so the constant cleaning or the equipment checking of filter and heat exchange element can be performed.

- The inspection opening shown below is necessary to clean the heat exchange element and the filter as required. If not cleaned, they are likely to get clogged, resulting in degradation of performance.
- Use forklift to carry in the Air to Air Heat Exchanger units and use winch or hoist at installation of them.

### ▼ VN-M150 to 1000HE

Unit: mm

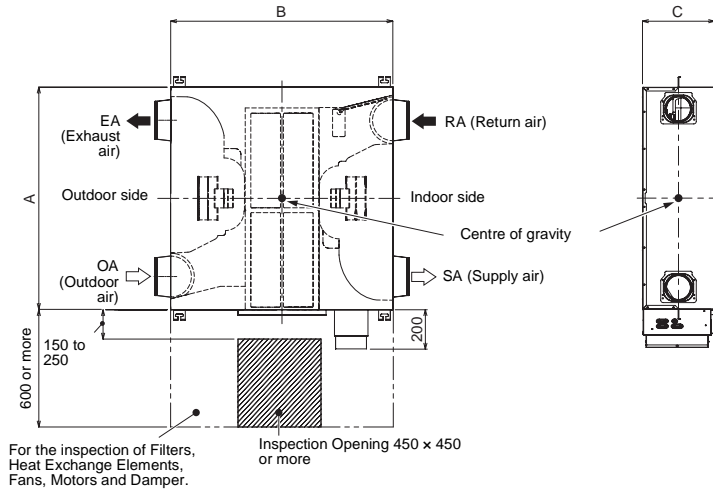

Model No.	A (mm)	B (mm)	C (mm)	Weight (kg)	Heat exchange element
VN-M150HE, M250HE	900	900	290	36	2
VN-M350HE	900	900	290	38	2
VN-M500HE, M650HE	1140	1140	350	53	2
VN-M800HE, M1000HE	1189	1189	400	70	2

### ▼ VN-M1500 and 2000HE

Unit: mm

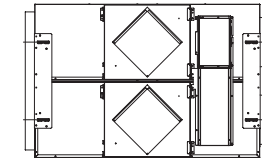
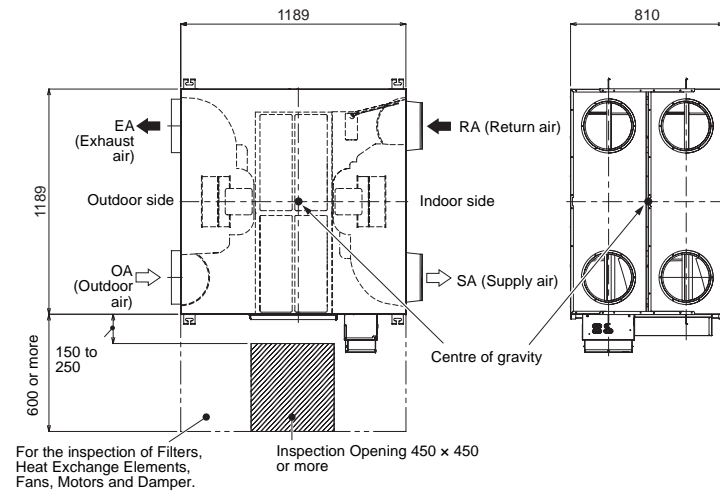

Weight: 143 kg  
Heat exchange element: 4

- **Helmet must be worn to protect your head from falling objects. Especially, when you work under an inspection opening, helmet must be worn to protect your head from falling objects from the opening.**

• **Observe the following conditions when using the Air to Air Heat Exchanger.**

Installation requirements : Temperature range -10 °C to +40 °C, relative humidity 80 % or less  
 Outdoor air conditions : Temperature range -15 °C to +43 °C, relative humidity 80 % or less  
 Return air conditions : Temperature range +5 °C to +40 °C, relative humidity 80 % or less

Do not install the Air to Air Heat Exchanger in a place where flames can come into contact with the unit. If the Air to Air Heat Exchanger is used for a long time without observing the conditions above, deterioration or deformation of resin parts will occur and a malfunction may result.

• **Dewing and frosting.**

- In cold regions, the surface of the unit or the duct connector may be affected by condensation or frosting depending on the outdoor air conditions or temperature / humidity of the ceiling cavity even though the conditions for use are observed. In this case, add a heat insulator.
- Do not install the unit in a place where there is something that must not become wet. Depending on the temperature or humidity of outdoor air and the installation place, water droplets may fall from the unit.
- As shown in the figure to the below, suppose a high temp absorbing air condition A and a low temp absorbing air condition B are plotted on the air line figure, then a high temp air A is heat-exchanged by the unit and goes out of the saturation curve as shown by Point C. In this case, the unit will be dewed or frosted. To avoid this, heating a low temp air B up to B' is required so as to get C' below the saturation curve, before using the unit.

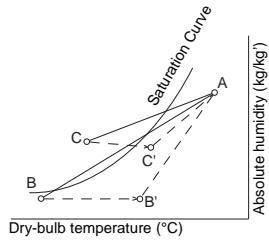

• **Refrain from the following duct installation works.**

- 1) Excessive bending
  - 2) Multi-times bending
  - 3) Making the connecting duct smaller
  - 4) Bending near the exhaust air duct
- 

- Do not install it near the water-heater
- Do not use in bathrooms or food preparation areas or in similar condition place. If the unit is used at the place of much soot and high humidity large amounts of oily smoke, the filter or the heat exchange element gets clogged and it will be disable to be use.
- Duct length must be longer than 850 mm.

# 4 Separately sold parts

**Wired remote controller (for the Air to Air Heat Exchanger)**

**NRC-01HE (Sold separately)**

Up to 8 units of the Air to Air Heat Exchanger can be operated using this remote controller.

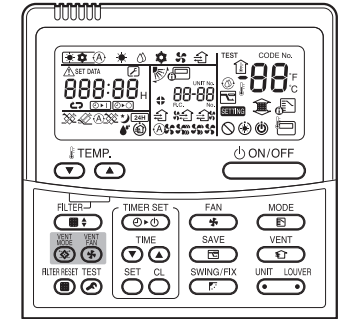

# 5 Reference diagram

▼ **VN-M150 to 1000HE**

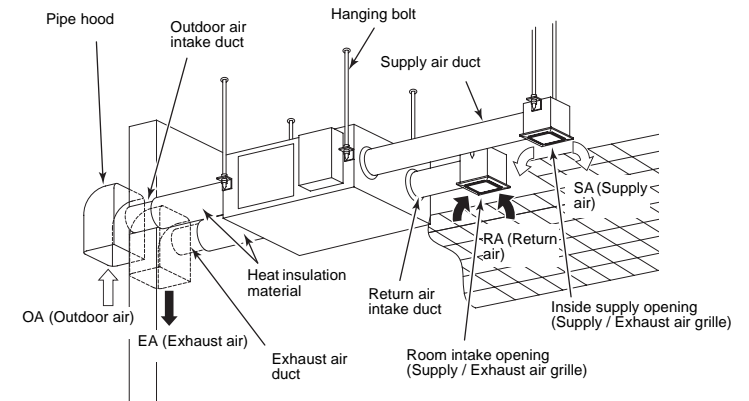

▼ **VN-M1500 and 2000HE**

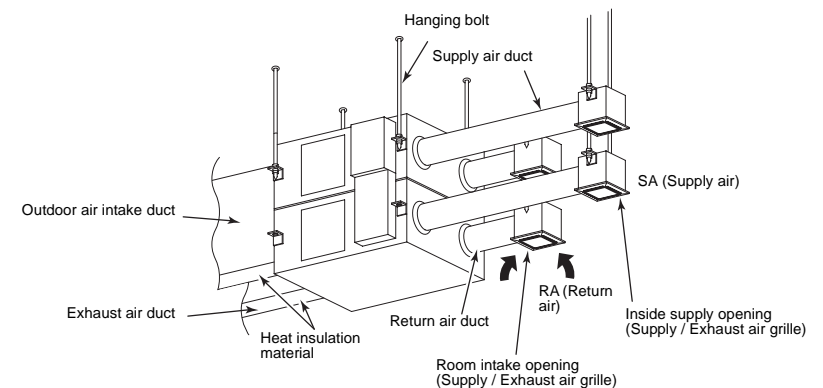

# 6 Model list

## ▼ VN-M150 to 1000HE

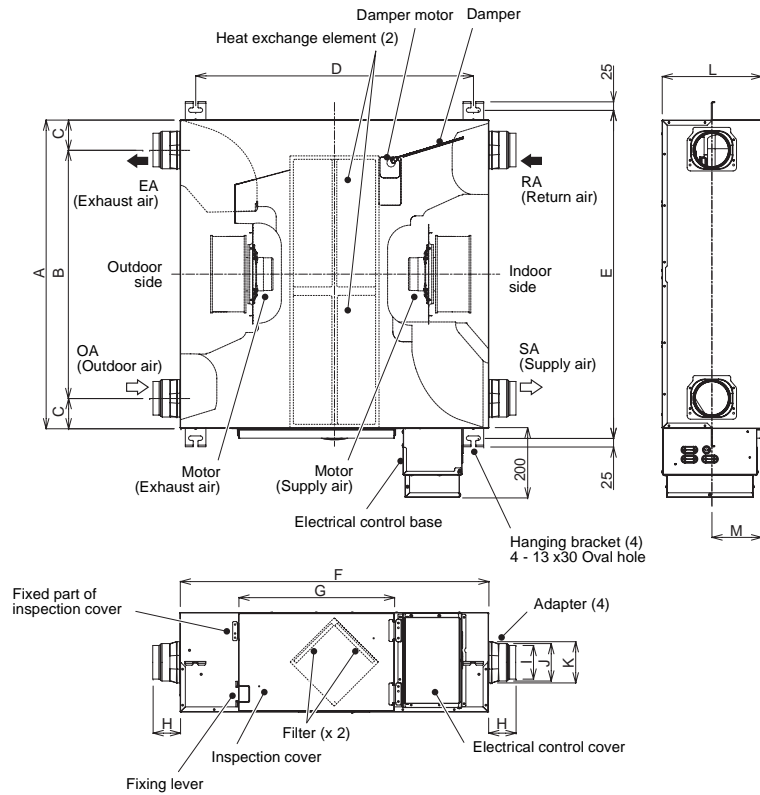

Unit: mm

Model name	A	B	C	D	E	F	G	H	I	J	K	L	M	Applicable duct nominal diameter
VN-M150HE	900	724	88	810	957	900	454	80	Ø98	Ø110	121	290	145	Ø100
VN-M250HE	900	670	115	810	957	900	454	97	Ø145	Ø158	162	290	145	Ø150
VN-M350HE	900	670	115	810	957	900	454	97	Ø145	Ø158	162	290	145	Ø150
VN-M500HE	1140	800	170	1050	1197	1140	454	80	Ø195	—	Ø212	350	175	Ø200
VN-M650HE	1140	800	170	1050	1197	1140	454	80	Ø195	—	Ø212	350	175	Ø200
VN-M800HE	1189	800	195	1099	1246	1189	454	85	Ø245	—	Ø262	400	200	Ø250
VN-M1000HE	1189	800	195	1099	1246	1189	454	85	Ø245	—	Ø262	400	200	Ø250

## ▼ VN-M1500 and 2000HE

Unit: mm

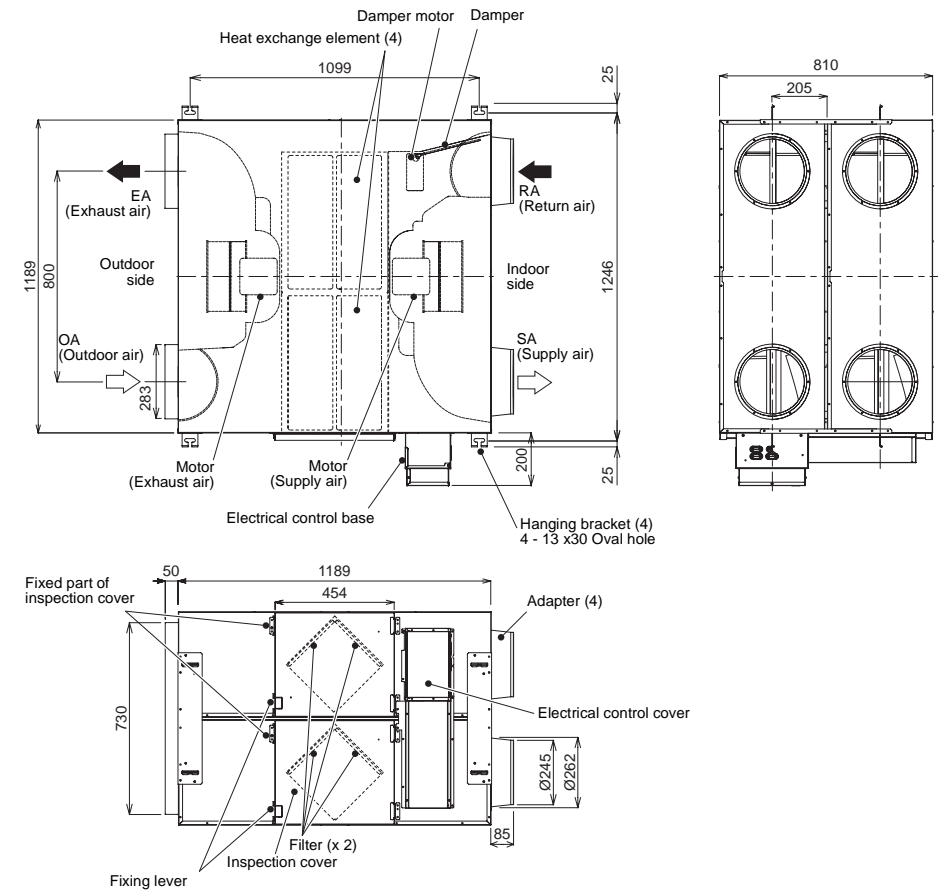

Applicable duct nominal diameter: indoor side Ø250  
 outdoor side 283 x 730

# 7 Installation

## ■ Attaching the adapter

Attach the adapter to the unit using the accessory screws (4 or 6).

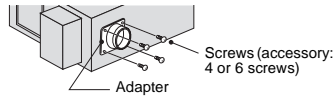

## ■ Attaching the washer and the nut

- 1) Preparation of the hanging bolt, nut, and washer is required.
- 2) Attach the washer and the nut to the hanging bolt (see the table on the below) according to the diagram on the below.

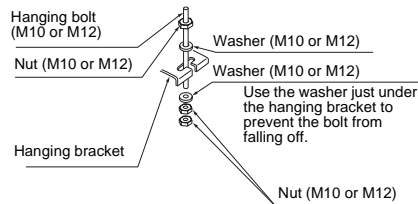

## ■ Fixing the unit

### ▼ VN-M150 to 1000HE

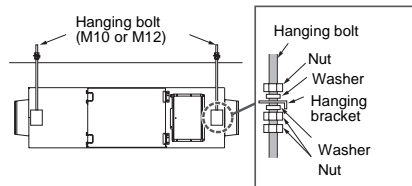

### ▼ VN-M1500 and 2000HE

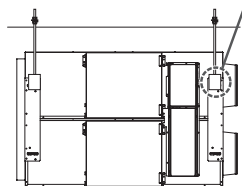

- 1) Hang the hanging bracket on the hanging bolt, then adjust the nut so that the unit is level.
- 2) Use a double nut and fasten it firmly so that the nut does not become loose.
  - If the unit is not installed properly, it will vibrate and may pose a hazard.
  - If the unit is not level, the damper unit will not work properly.
  - Install the unit firmly enough to support its own weight.

Model name	Weight (kg)	Hanging bolt
VN-M150HE	36	M10, M12
VN-M250HE	36	
VN-M350HE	38	
VN-M500HE	53	
VN-M650HE	53	
VN-M800HE	70	
VN-M1000HE	70	
VN-M2000HE	140	

## ⚠ CAUTION

- Use a commercially available vibration-proof fixture when the unit is installed in a place where preventing vibration is necessary.
- Leave a space of 450 mm x 450 mm or more for checking the filter, heat exchanging element, power source, or motor. Refer to "Cautions for installation" for the location of the space required.

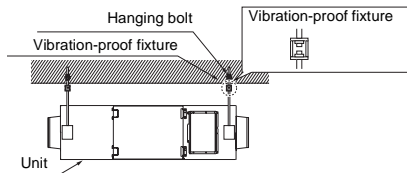

## ■ Cautions installing unit body upside down

- The hanging bracket does not need to be replaced.
- The printed image is reversed.

## ■ Duct installation

- Duct installation is necessary to protect against access to live parts, rain water or contact with moving parts.
- Seal the junction of an adaptor and a duct with an aluminium tape firmly to prevent any air leakage.
- The room intake opening should be positioned as far as possible from the indoor supply opening.
- Use the specified ducts. (See the Model List)
- Install two outdoor ducts so they will be in the down gradient toward outdoor to prevent water from coming in. (Gradient: 1/100~1/50) (See the figure below)  
Heat-insulate two outdoor ducts (including outdoor air and exhaust air duct) to prevent dewing. (Material: Glass Wool, Thickness-25 mm) (See the figure below)  
To pierce the metal duct through the metal lath or the wire lath or the metal plate of the wooden facility, insulate electrically between the duct and the wall. (Refer to the laws and regulations of the country concerned and the technical standard.)

### ▼ VN-M150 to 1000HE

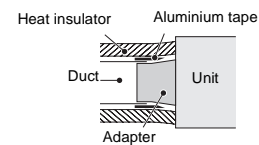

### ▼ VN-M1500 and 2000HE

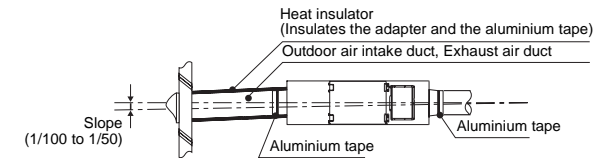
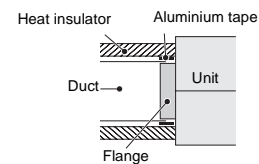

- It is recommended that an electric damper is used together with the Air to Air Heat Exchanger, as wind may enter the room while the unit is not in operation in windy places.



## 8 Electric wiring

### ⚠ WARNING

- Using the specified wires, ensure to connect the wires, and fix wires securely so that the external tension to the wires do not affect the connecting part of the terminals.  
Incomplete connection or fixation may cause a fire or other troubles.
- Connect earth wire. (grounding work)**  
Incomplete earthing cause an electric shock.  
Do not connect earth wires to gas pipes, water pipes, lightning rods or earth wires for telephone wires.
- Appliance shall be installed in accordance with national wiring regulations.**  
Capacity shortage of power circuit or incomplete installation may cause an electric shock or a fire.

### ⚠ CAUTION

- If incorrect / incomplete wiring is carried out, it will cause an electrical fire or smoke.
- Install an earth leakage breaker that is not tripped by shock waves.  
If an earth leakage breaker is not installed, an electric shock may be caused.
- Use the cord clamps attached to the product.
- Do not damage or scratch the conductive core and inner insulator of power and communication wires when peeling them.
- Use the power and communication wire of specified thickness, type, and protective devices required.
- Do not connect 220-240 V power to the communication terminal blocks (ⓐ, ⓑ, Ⓐ, Ⓑ) for control wiring.  
(Otherwise, the system will fail.)

### REQUIREMENT

- For power supply wiring, strictly conform to the Local Regulation in each country.
- After connecting wires to the terminal blocks, provide a trap and fix wires with the cord clamp.

## ■ Power and wiring specifications

Power supply wire and communication wire should be locally procured.

See the table below for the power supply specifications. If the capacity is too small, the unit will suffer from overheating or burnout.

Model name VN-		Power supply for Air to Air Heat Exchanger (*1)		
		Power supply	Circuit breaker (switch)	Power supply wire
Current rating (Fuse rating)				
Air to Air Heat Exchanger	M150HE to M2000HE	220 V-240 V~, 50 Hz 220 V~, 60 Hz	15 A	3-core, 1.5 mm <sup>2</sup> or 2.5 mm <sup>2</sup> (H07 RN-F or 60245 IEC 66)

\*1: Prepare the exclusive power supply for the Air to Air Heat Exchanger

## ■ Communication wire

Item		Communication wire	
		Central control wire (*2)	Remote controller wire
Air to Air Heat Exchanger	M150HE to M2000HE	2-core, non-polarity Shielded wire (Up to 1000 m) 1.25 mm <sup>2</sup> (Up to 2000 m) 2.0 mm <sup>2</sup>	2-core, non-polarity 0.5 mm <sup>2</sup> to 2.0 mm <sup>2</sup>

\*2:

- The length of the communication wire is the total length of the outdoor / indoor transition wire and wire of the central control assuming that an interlocking system with the indoor unit or central control system is used.
- To prevent noise, use a 2 core shielded wire.

## ■ Remote controller wiring

Remote controller wiring, remote controller inter-unit wiring	2-core, non-polarity: 0.5 mm <sup>2</sup> to 2.0 mm <sup>2</sup>
---	--

Total wire length of remote controller wiring and remote controller inter-unit wiring = L + L1 + L2 + ... Ln	Up to 500 mm
Total wire length of remote controller inter-unit wiring = L1 + L2 + ... Ln	Up to 200 mm

On the outside of the unit, do not allow the wire for the remote controller (communication wire) and the wire for AC220-240 V to come into contact or put them together in one electrical conduit; otherwise, the control system may have trouble due to noise.

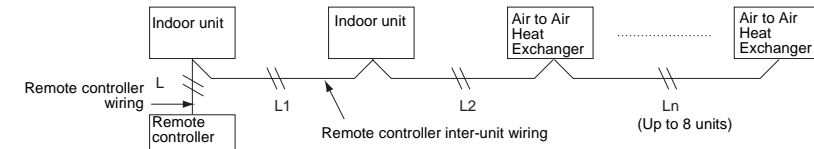

\* The total length of the remote controller inter-unit wiring is the same for both between the indoor units and between the Air to Air Heat Exchanger.

### Connection diagram

#### ▼ VN-M150 to 1000HE

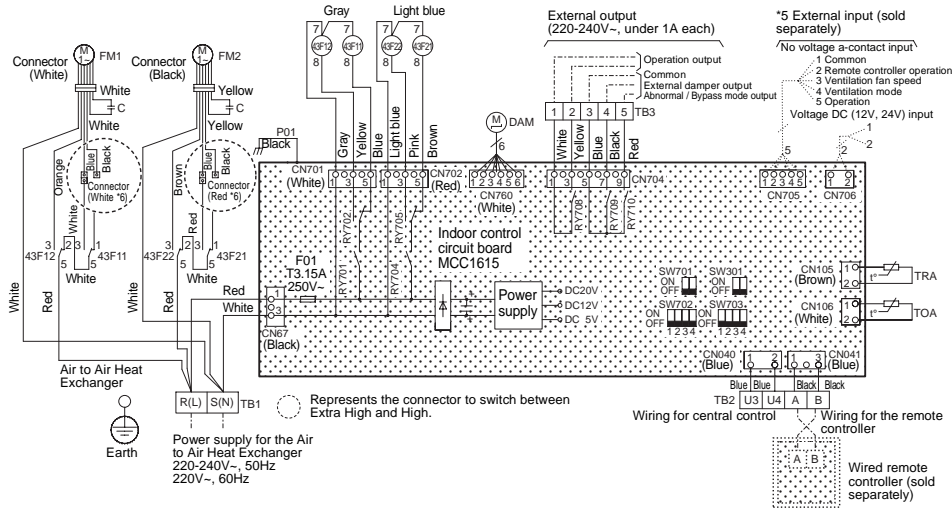

Code	Part name	Code	Part name	Code	Part name
CN***	Connector	TOA	TOA sensor	SW301, SW701 SW702, SW703	DIP switch
F01	Fuse	RY701, RY702	Relay for air supplying motor	43F11, 43F12	Relay for air supplying motor
FM1	Air supplying motor	RY704, RY705	Relay for air exhausting motor	43F21, 43F22	Relay for air exhausting motor
FM2	Air exhausting motor	TB1	Terminal block (power supply)		
DAM	Damper motor	TB2	Terminal block (communication)		
TRA	TRA sensor	TB3	Terminal block (external output)		

- The dotted line represents a wire locally procured, and the dashed line represents an option sold separately.
- represents a terminal block, —○ represents a connection terminal, and ○ represents a connector on the printed circuit board.
- ⊕ represents a protective ground.
- PCB represents a printed circuit board.
- Using a no voltage a-contact input of the external input (sold separately), the following operations are available:  
 Between 1 and 2: Selecting the remote controller operation (Invalid / Valid)  
 Between 1 and 3: Adjusting the ventilation fan speed (Low / High)  
 Between 1 and 4: Selecting the ventilation mode (Bypass mode / Heat exchange mode)  
 Between 1 and 5: Operation (ON/OFF)  
 Use a microcurrent contact (DC12 V, 1 mA). In addition, ON/OFF operation is possible when using a voltage of DC12 V or 24 V.
- Blue wire (High) is connected as factory default. To switch to "Extra High", connect black wire's connector instead of blue.
- When the temperature of the outdoor air is below -10 °C, the unit runs in the cold mode (the ventilator for air supply runs intermittently). The unit cannot run when the temperature of the outdoor air is below -15 °C. The ventilator for air supply stops running and the ventilator for air exhaust also stops depending on the settings.
- Even if "Bypass mode" is selected manually, the unit switches to "Heat exchange mode" automatically to prevent condensation when the temperature of the outdoor air is below 15 °C. However, "Bypass mode" is still displayed.

#### ▼ VN-M1500 and 2000HE

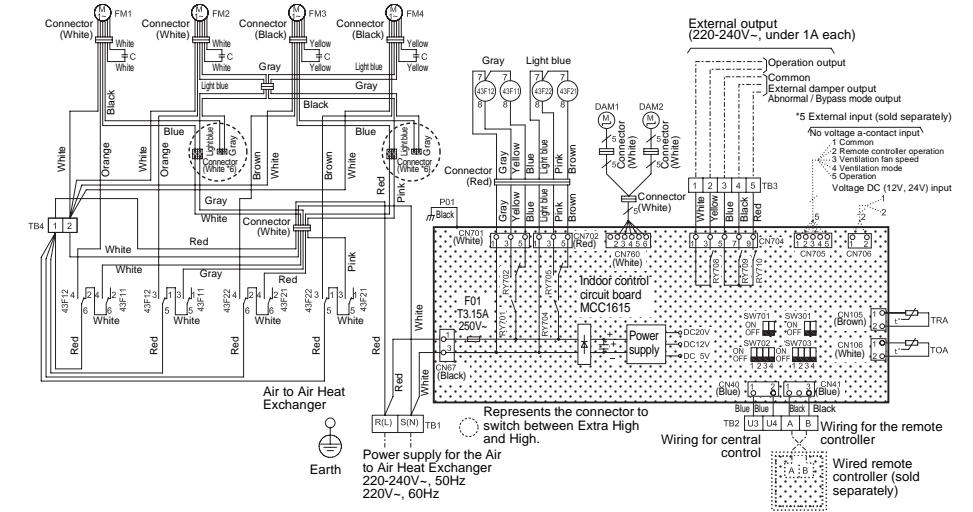

Code	Part name	Code	Part name	Code	Part name
CN***	Connector	TOA	TOA sensor	TB4	Terminal block
F01	Fuse	RY701, RY702	Relay for air supplying motor		
FM1, FM3	Air supplying motor	RY704, RY705	Relay for air exhausting motor		
FM2, FM4	Air exhausting motor	TB1	Terminal block (power supply)	43F11, 43F12	Relay for air supplying motor
DAM1, DAM2	Damper motor	TB2	Terminal block (communication)	43F21, 43F22	Relay for air exhausting motor
TRA	TRA sensor	TB3	Terminal block (external output)		

- The dotted line represents a wire locally procured, and the dashed line represents an option sold separately.
- represents a terminal block, —○ represents a connection terminal, and ○ represents a connector on the printed circuit board.
- ⊕ represents a protective ground.
- PCB represents a printed circuit board.
- Using a no voltage a-contact input of the external input (option), the following operations are available:  
 Between 1 and 2: Selecting the remote controller operation (Invalid / Valid)  
 Between 1 and 3: Adjusting the ventilation fan speed (Low / High)  
 Between 1 and 4: Selecting the ventilation mode (Bypass mode / Heat exchange mode)  
 Between 1 and 5: Operation (ON/OFF)  
 Use a microcurrent contact (DC12 V, 1 mA). In addition, ON/OFF operation is possible when using a voltage of DC12 V or 24 V.
- Blue wire (High) is connected as factory default. To switch to "Extra High", connect black wire's connector instead of blue.

## Switches and connectors on the circuit board

Remove the 4 screws to detach the electrical control cover.

\* Refer to "9. Installation method for each system configuration" on page 11 about setting the switch.

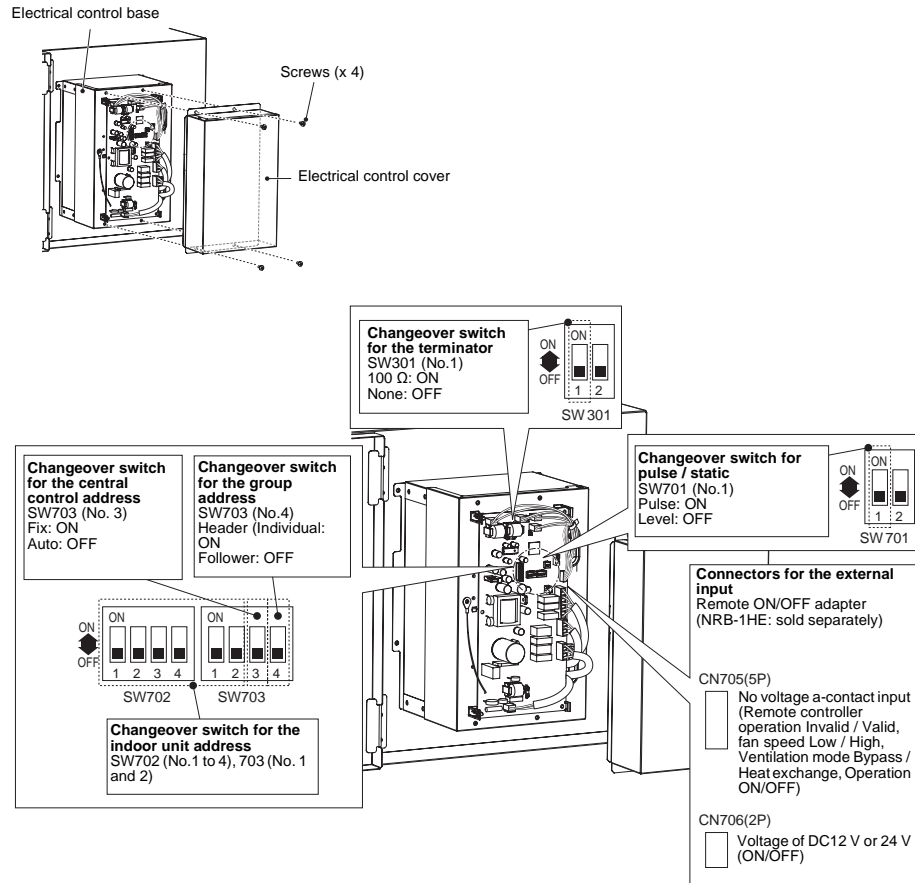

## Wire connection

In a central control system, connect the copper braid shield of central control wire (2-core shielded wire).

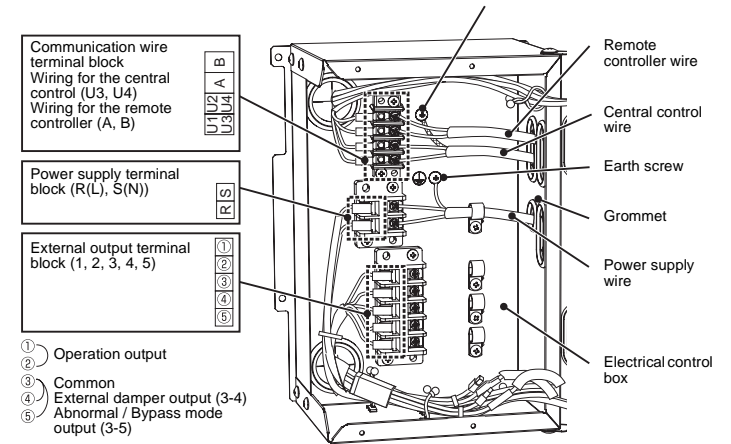

Power supply wire

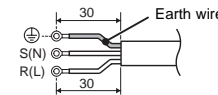

Central control wire

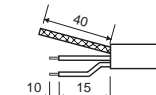

Remote controller wire

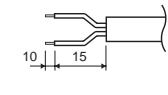

### REQUIREMENT

- Pass the wires through the grommet of wiring connection holes of the Air to Air Heat Exchanger.
- Keep a margin (Approx. 100 mm) on a wire.
- The low-voltage circuit is provided for the remote controller.
- Rotate the electrical control base to open.
- Connect the power supply wire (R (L), S (N)) and the remote controller wire (A, B).
- Connect the central control wire (U1 / U3, U2 / U4) or the external output terminal block (1 to 5) if necessary.
- Tighten the screws on the terminal board firmly, then fix the wiring on the electrical control box using the accessory cord clamp.
- Perform grounding work.

### Switching between extra high and high

#### WARNING

Turn off the circuit breaker before switching between Extra High and High.

When switching to Extra High, connect the black lead wire (Extra High) to the connector.

- \* The blue lead wire (High) is connected as factory default.
- \* Connect the black lead wire both to the supplying air motor (white connector) and the exhausting air motor (red connector).
- \* Refer to "Connection diagram" for the connection method.

#### REQUIREMENT

After connecting the black lead wire to the connectors, fix the lead wires using the cord clip.

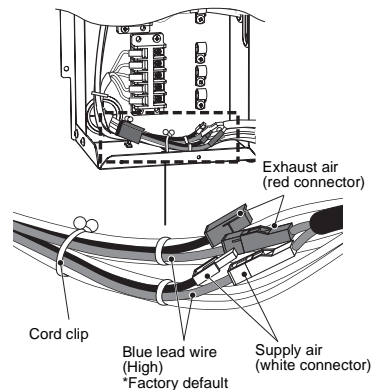

### Remote controller wiring

- As the remote controller wire has non-polarity, there is no problem if connections to Air to Air Heat Exchanger terminal blocks A and B are reversed.

#### Wiring diagram

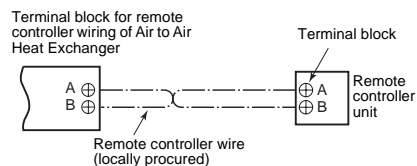

- \* For details of wiring / installation of the remote controller, refer to the Installation Manual enclosed to in the remote controller.

## 9 Installation method for each system configuration

Settings and electric wiring differ depending on the system configuration. Perform electric wiring according to the system examples shown in the table below. (Refer to page 14 to 16 for details.)

System example	Operation
<p><b>A] Air to Air Heat Exchanger system</b> (One Air to Air Heat Exchanger is used.)</p>	<ul style="list-style-type: none"> <li>• Using the remote controller for the Air to Air Heat Exchanger NRC-01HE, the unit can be started or stopped, control the ventilation fan speed, and select the ventilation mode.</li> <li>• If two remote controllers are used, the latter operation overrides the former and their indications always reflect the result of the latter operation.                     <ul style="list-style-type: none"> <li>* The remote controllers for the air conditioners RBC-AMT32E are not compatible with a system in which only the Air to Air Heat Exchanger is used. Only on/off operation is available for RBC-AMS41E.</li> </ul> </li> </ul>
<p><b>B] Air to Air Heat Exchanger system</b> (Multiple Air to Air Heat Exchangers are used.)</p>	<ul style="list-style-type: none"> <li>• Using the remote controller for the Air to Air Heat Exchanger NRC-01HE, the unit can be started or stopped, control the ventilation fan speed, and select the ventilation mode.</li> <li>• If two remote controllers are used, the latter operation overrides the former and their indications always reflect the result of the latter operation and the settings of the header unit.                     <ul style="list-style-type: none"> <li>* The remote controllers for the air conditioners RBC-AMT32E are not compatible with a system in which only the Air to Air Heat Exchanger is used. Only on/off operation is available for RBC-AMS41E.</li> </ul> </li> </ul>
<p><b>C] Air to Air Heat Exchanger system linked with air conditioners</b></p>	<ul style="list-style-type: none"> <li>• The remote controller for the air conditioner or the Air to Air Heat Exchanger can be used to ON/OFF the whole system.</li> <li>• The remote controller for the Air to Air Heat Exchanger NRC-01HE can be used to control the ventilation fan speed and ventilation mode of the Air to Air Heat Exchanger.</li> <li>• The remote controller for air conditioner RBC-AMT32E and RBC-AMS41E cannot be used to control the ventilation fan speed or ventilation mode of the Air to Air Heat Exchanger.</li> <li>• The remote controller for the air conditioner or the Air to Air Heat Exchanger can be used to ON/OFF the Air to Air Heat Exchanger separately.                     <ul style="list-style-type: none"> <li>* Setting modifications are required for separate control. Refer to "11. Advanced control" on page 19.</li> </ul> </li> <li>• If two remote controllers are used, the latter operation overrides the former and their indications always reflect the result of the latter operation. In addition, the indications of the Air to Air Heat Exchanger always reflect the setting of the unit with the smallest indoor unit address number.</li> </ul>

System example	Operation
<p><b>D Central control system</b> (When controlling the Air to Air Heat Exchanger only)</p> <p>Central controller for 64/128 units / groups (TCB-SC642TLE2, BMS-CM1280TLE)</p> <p>Remote controller for the Air to Air Heat Exchanger (NRC-01HE)</p> <p>Remote controller for air conditioner (RBC-AMS41E)</p>	<ul style="list-style-type: none"> <li>The central controller can be used to ON/OFF the whole system and separately ON/OFF groups of the Air to Air Heat Exchangers.</li> <li>The central controller cannot be used to control the ventilation fan speed or ventilation mode of the Air to Air Heat Exchanger.</li> <li>If the central controller and the remote controller for the Air to Air Heat Exchanger are used, the latter operation overrides the former.</li> <li>The remote controller for the Air to Air Heat Exchanger (NRC-01HE) can be used to control the ventilation fan speed and ventilation mode of the Air to Air Heat Exchanger.</li> <li>* The remote controllers for the air conditioners (RBC-AMT32E) cannot be used to control the group of the Air to Air Heat Exchangers. Only on/off operation is available for RBC-AMS41E.</li> </ul>
<p><b>E Central control system</b> (When controlling the air conditioner and the Air to Air Heat Exchanger separately)</p> <p>Central controller for 64/128 units / groups (TCB-SC642TLE2, BMS-CM1280TLE)</p> <p>Remote controller for the air conditioner (RBC-AMT32E, RBC-AMS41E)</p> <p>Remote controller for the Air to Air Heat Exchanger (NRC-01HE)</p> <p>Remote controller for air conditioner (RBC-AMS41E)</p>	<ul style="list-style-type: none"> <li>The central controller can be used to ON/OFF the whole system and separately ON/OFF groups of air conditioners and the Air to Air Heat Exchangers. (Air conditioners and Air to Air Heat Exchangers are not linked in this system.)</li> <li>The central controller cannot be used to control the ventilation fan speed or ventilation mode of the Air to Air Heat Exchanger.</li> <li>The operation of the central controller overrides that of the remote controllers for the Air to Air Heat Exchangers and the air conditioners. However, the operation of the remote controller for the Air to Air Heat Exchanger does not affect that of the remote controller for the air conditioner and vice versa.</li> <li>The remote controller for the Air to Air Heat Exchanger (NRC-01HE) can be used to control the group of the air conditioners instead of using the remote controller for the air conditioner.</li> <li>The remote controller for the Air to Air Heat Exchanger (NRC-01HE) can be used to control the ventilation fan speed and ventilation mode of the group of the Air to Air Heat Exchangers.</li> <li>* The remote controllers for the air conditioners (RBC-AMT32E) cannot be used to control the group of the Air to Air Heat Exchangers. Only on/off operation is available for RBC-AMS41E.</li> </ul>
<p><b>F Central control system</b> (When controlling the air conditioner and Air to Air Heat Exchanger together)</p> <p>Central controller for 64/128 units / groups (TCB-SC642TLE2, BMS-CM1280TLE)</p> <p>Remote controller for air conditioner (RBC-AMT32E, RBC-AMS41E)</p> <p>Remote controller for the Air to Air Heat Exchanger (NRC-01HE)</p>	<ul style="list-style-type: none"> <li>The central controller can be used to ON/OFF the whole system. It can also be used to ON/OFF the Air to Air Heat Exchanger separately (*).</li> <li>The central controller cannot be used to control the ventilation fan speed or ventilation mode of the Air to Air Heat Exchanger.</li> <li>If three control devices are used; the central controller and the remote controllers for the Air to Air Heat Exchanger and the air conditioner, the latter operation overrides the former regardless of which device is used.</li> <li>The remote controller for the Air to Air Heat Exchanger NRC-01HE can be used to control the ventilation fan speed and ventilation mode of the Air to Air Heat Exchanger.</li> <li>If the remote controller for the air conditioner (RBC-AMT32E and RBC-AMS41E) is used; the ventilation fan speed or ventilation mode of the Air to Air Heat Exchanger can not be controlled.</li> <li>The remote controller for the air conditioner or the Air to Air Heat Exchanger can be used to ON/OFF the Air to Air Heat Exchanger separately.</li> <li>* Setting modifications are required for separate control. Refer to "11. Advanced control" on page 19.</li> </ul>

	Air to Air Heat Exchanger system		Air to Air Heat Exchanger system linked with air conditioners	
System example	A	B	—	C
Central control	None			
No. of Air to Air Heat Exchangers	1	Multiple	1	Multiple
Operation together with the air conditioners	No		Yes	
Remote controller inter-unit wiring	Not necessary	Necessary		
Central control wiring	Not necessary			
Circuit board of the Air to Air Heat Exchanger	1. Line (system) address	Fixed * The line (system) address is fixed as 31 for the Air to Air Heat Exchanger.		
	2. Changing the indoor unit address No. 1 to 4 of SW702 No. 1 and 2 of SW703	Not necessary Factory default: 1	Necessary No duplication Factory default: 1	Not necessary Factory default: 1
	3. Changing the group address No. 4 of SW703	Necessary Header (Individual): ON	Necessary Header: ON (1unit) Follower: OFF (the other units) * Settings of the header unit reflect the indications of the remote controller.	Not necessary Follower: OFF (all units) * Settings of the follower unit with the smallest indoor unit address number reflect the indication of the remote controller.
	4. Fix / Automatic changeover of the central control address No. 3 of SW703	Not necessary		
	5. Changing the terminator No. 1 of SW301	Not necessary None: OFF		
Checking before turning on the power	Complete the settings of the Air to Air Heat Exchanger and wiring.		<ul style="list-style-type: none"> <li>Complete the settings of the Air to Air Heat Exchanger and wiring.</li> <li>Refer to the Installation Manual of the air conditioner for the settings and wiring.</li> </ul>	
Turning on the power	Turn on the breaker of all the Air to Air Heat Exchangers.		Turn on the Air to Air Heat Exchanger first. Refer to the Installation Manual of the air conditioner for its power supply.	
Central control address setting	Not necessary			



## ■ Installing two remote controllers for the Air to Air Heat Exchanger

For details on how to install the remote controller for the Air to Air Heat Exchanger, refer to the Installation Manual accessory with the remote controller.

One or multiple Air to Air Heat Exchanger(s) can be controlled by using two remote controllers. (Up to two remote controllers can be installed.)

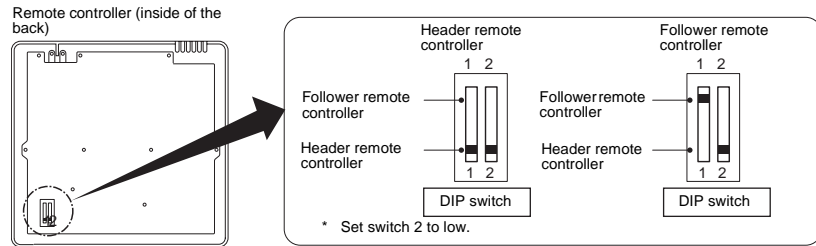

### How to install

To use two remote controllers, follow the procedure below.

1. Set one remote controller as the header (factory default).
2. Set the other remote controller as the follower using the DIP switch. After that, the remote controller works as the follower.

## ■ Settings for each system configuration

### NOTE

The line (system) address is fixed as 31 for the Air to Air Heat Exchanger.

### A Air to Air Heat Exchanger system (One Air to Air Heat Exchanger is used.)

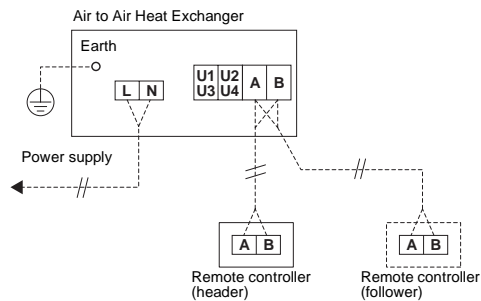

#### Changing the group address (No.4 of SW703)

Settings for changing the group address are necessary. Select "Header: ON". (Factory default: Follower)

\* When "Header: ON" is selected, "Individual: ON" will be selected in this system.

#### Changing the indoor unit address (No.1 to 4 of SW702, No.1 and 2 of SW703)

The setting does not need to be adjusted. (Factory default: 1)

### B Air to Air Heat Exchanger system (Multiple Air to Air Heat Exchangers are used.)

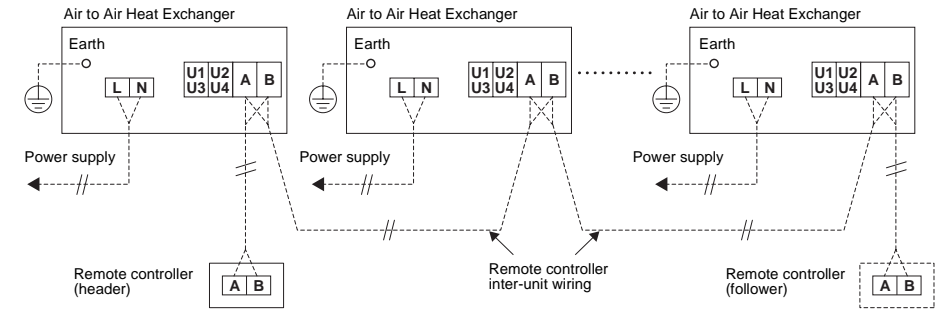

- \* For group control, install remote controller inter-unit wiring between the units.
- \* Up to 8 units can be installed for group control.

#### Changing the group address (No.4 of SW703)

Settings for changing the group address are necessary. Select "Header: ON" for only one unit. Select "Follower" for the other units.

\* Settings of the header unit reflect the indications of the remote controller. (Factory default: Follower)

#### Changing the indoor unit address (No.1 to 4 of SW702, No.1 and 2 of SW703)

Settings for changing the indoor unit address are necessary. Do not duplicate the value. (1 to 64)

\* The header unit does not need to be selected as "1". (Factory default: 1)

### C Air to Air Heat Exchanger system linked with air conditioners

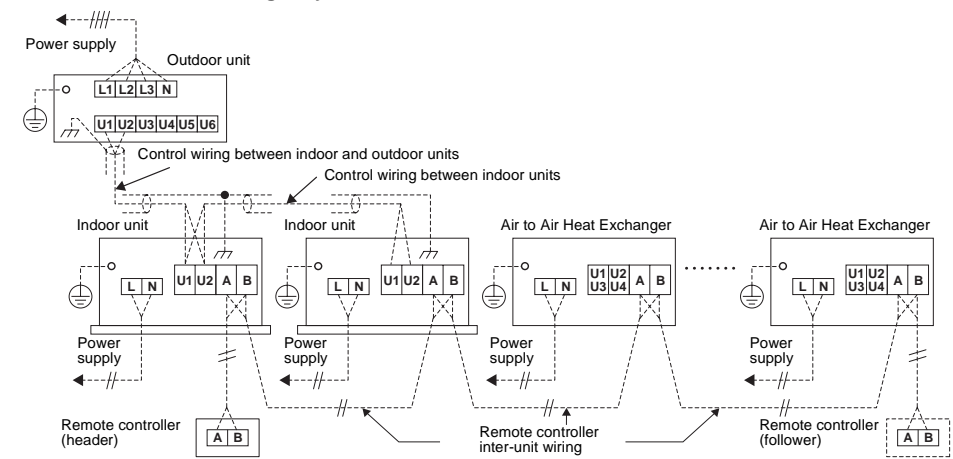

- \* For group control with air conditioners, install inter-unit wiring between the units.
- \* Up to 8 units can be installed for group control.

#### Changing the group address (No.4 of SW703)

The settings of the group address does not need to be adjusted. Leave the value "Follower: OFF". (Factory default: Follower)

\* Settings of the follower unit with the smallest indoor unit address number reflect the indication of the remote controller.

#### Changing the indoor unit address (No.1 to 4 of SW702, No.1 and 2 of SW703)

Settings for changing the indoor unit address are necessary. Do not duplicate the value. (1 to 64) (Factory default: 1)

**D Central control system (When controlling the Air to Air Heat Exchanger only)**

For the settings of the central control address, refer to the Installation Manual of the central control device.

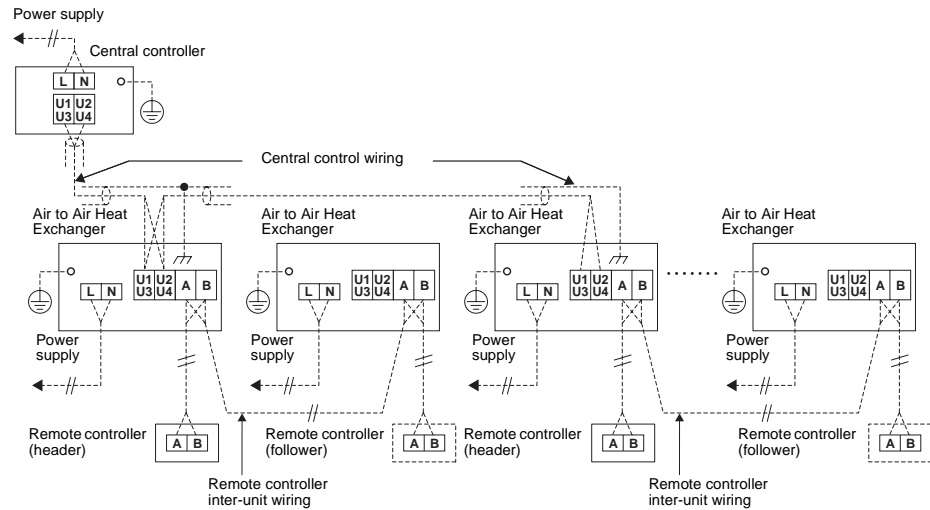

- \* Central control wiring must be connected to the header Air to Air Heat Exchanger unit only.
- \* For group control, install inter-unit wiring between the units.
- \* Up to 8 units can be installed for group control.

**Changing the group address (No.4 of SW703)**

Settings for changing the group address are necessary. Select "Header: ON" on the header unit of each group which central control wiring is connected to. Select "Follower" for the other units.

- \* Settings of the header unit reflect the indications of the remote controller. (Factory default: Follower)

**Changing the indoor unit address (No.1 to 4 of SW702, No.1 and 2 of SW703)**

Settings for changing the indoor unit address are necessary. Do not duplicate the value. (1 to 64)

- \* The header unit does not need to be selected as "1". (Factory default: 1)

**Changing the terminator (No.1 of SW301)**

Settings for changing the terminator are necessary. Select "ON" for one of the header unit.

- (Factory default: OFF)
- 100 Ω: ON (1 header unit only)
- None: OFF (the other units)

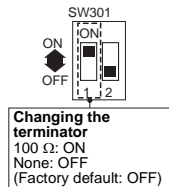

**E Central control system (When controlling the air conditioner and the Air to Air Heat Exchanger separately)**

For the settings of the central control address, refer to the Installation Manual of the central control device.

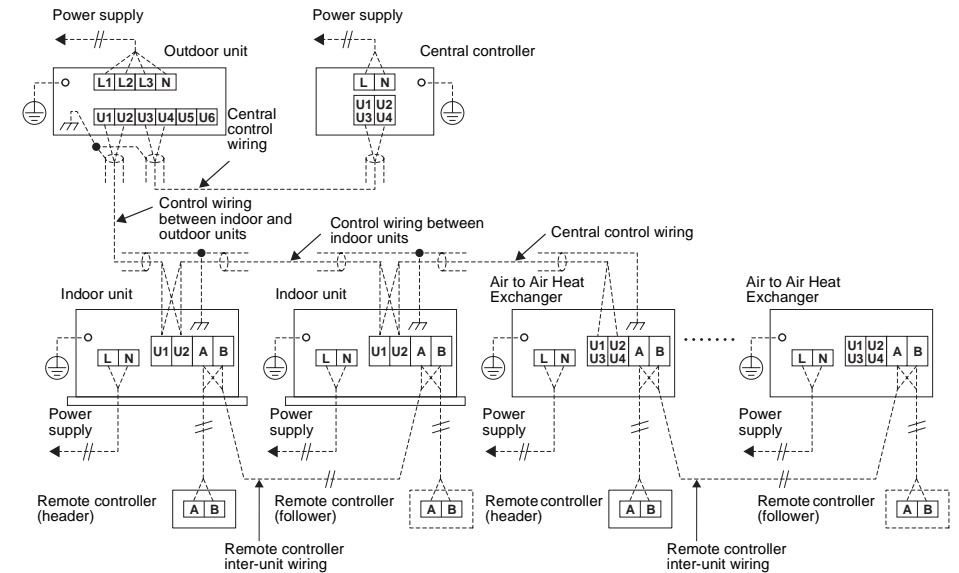

- \* Central control wiring of the Air to Air Heat Exchanger is necessary only for the header unit.
- \* For group control, install inter-unit wiring between the units.
- \* Up to 8 units can be installed for group control.

**Changing the group address (No.4 of SW703)**

Settings for changing the group address are necessary. Select "Header: ON" on the header unit of each group which central control wiring is connected to. Select "Follower" for the other units.

- \* When "Header: ON" is selected, "Individual: ON" will be selected if only one Air to Air Heat Exchanger is connected to this system.

- \* Settings of the header unit reflect the indications of the remote controller. (Factory default: Follower)

**Changing the indoor unit address (No.1 to 4 of SW702, No.1 and 2 of SW703)**

Settings for changing the indoor unit address are necessary. Do not duplicate the value. (1 to 64)

- \* The header unit does not need to be selected as "1". (Factory default: 1)

**Changing the terminator (No.1 of SW301)**

- \* The settings do not need to be adjusted.



### F Central control system (When controlling the air conditioner and Air to Air Heat Exchanger together)

- For the settings of the central control address, refer to the Installation Manual of the central control device.
- Do not perform the central control wiring with the Air to Air Heat Exchanger.

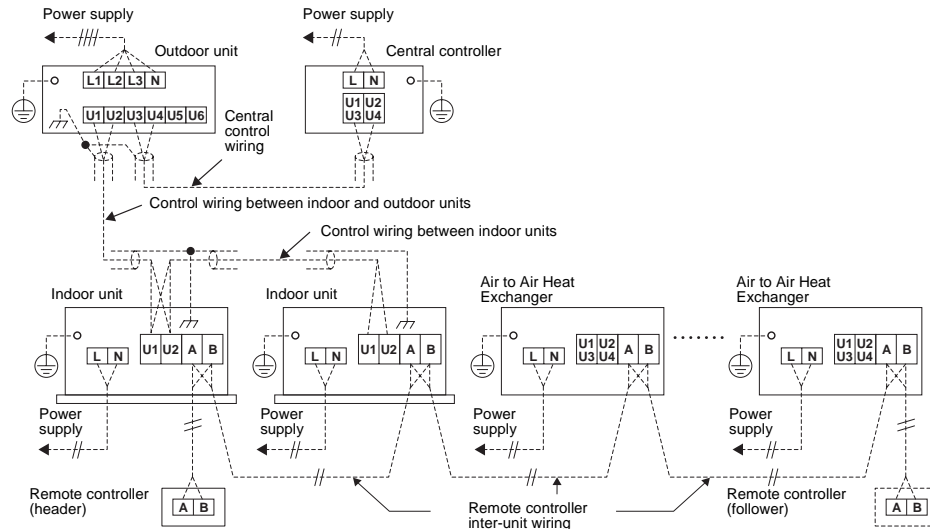

- \* For group control with air conditioners, perform inter-unit wiring between the units.
- \* Up to 8 units can be installed for group control.

#### Changing the group address (No.4 of SW703)

The settings of the group address does not need to be adjusted. Leave the value "Follower: OFF". (Factory default: Follower)

- \* The settings of the follower unit with the smallest indoor unit address number reflect the indication of the remote controller.

#### Changing the indoor unit address (No.1 to 4 of SW702, No.1 and 2 of SW703)

Settings for changing the indoor unit address are necessary. Do not duplicate the value. (1 to 64) (Factory default: 1)

#### Changing the terminator (No.1 of SW301)

- \* The settings do not need to be adjusted.

# 10 Advanced system

## ⚠ WARNING

- Use wiring that meets the specifications in the Installation Manual and the stipulations in the local regulations and laws. Use of wiring which does not meet the specifications may give rise to electric shocks, electrical leakage, smoking and/or a fire.
- When carrying out electric connection, use the wire specified in the Installation Manual and connect and fix the wire securely to prevent them applying external force to the terminals. Improper connection of fixing may result in fire.
- Electrical wiring work shall be conducted according to law and regulation in the community and Installation Manual. Failure to do so may result in electrocution or short circuit.

## REQUIREMENT

For the connecting procedure and electric wiring of External Input (sold separately), refer to the Installation Manual of Remote ON/OFF Adapter NRB-1HE.

### 1 When the operation is linked by a signal from an external device or remotely controlled On and Off. (Separately sold External Input)

## REQUIREMENT

Do not change the setting of the Air to Air Heat Exchanger single operation for Air to Air Heat Exchangersystem linked with air conditioners on page 21.

- \* Operating together if a command is sent to one of the units in the group.
- \* Setting for linked operation with external devices can be changed. Refer to the "Setting for linked operation with external devices" on page 22.

#### • When a remote controller is used with the Air to Air Heat Exchanger

The latter operation of the remote controller or the switch of the external device overrides the former. (Single operation of Air to Air Heat Exchanger is possible.)

#### • When no remote controller is used with the Air to Air Heat Exchanger

The operation of the Air to Air Heat Exchanger is confined to that together with the external device. (Single operation of Air to Air Heat Exchanger is not possible.)

### 1) When the output signal of the external device is DC12 V or DC24 V (static signal)

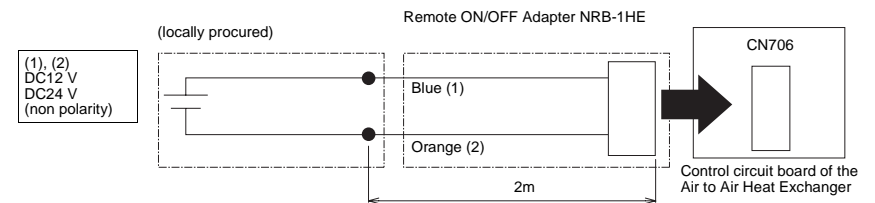

- Transmission wire used to extend must be locally procured: Non-polarity, 2-core wire 0.5 mm<sup>2</sup> Maximum length: Refer to the external device's manual.
- Insert the Remote ON/OFF Adapter NRB-1HE (sold separately) into connector CN706 (2P).
- If a command is sent to one of the units in the group, all the air conditioners and the Air to Air Heat Exchanger operate together.

## 2) When the output signal of the external device is a no voltage a-contact (static signal)

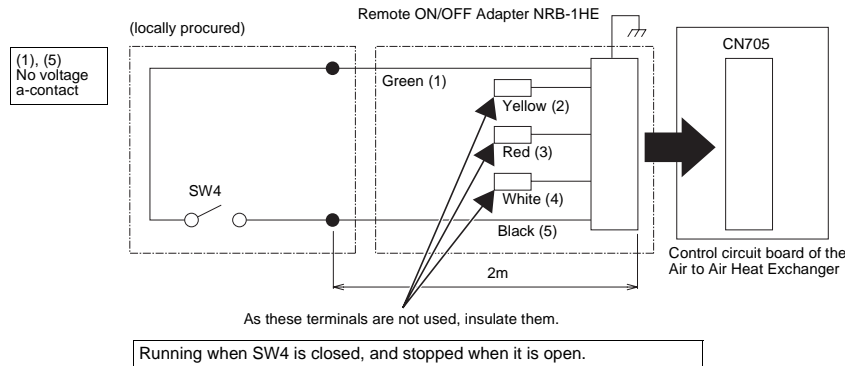

- Transmission wire used to extend must be locally procured: Non-polarity, shielded wire (H05 VVC4V5-K or 60227 IEC 74) 0.5 mm<sup>2</sup> Maximum length: 50 m
- Insert the Remote ON/OFF Adapter NRB-1HE (sold separately) into connector CN705 (5P).
- If a command is sent to one of the units in the group, all the air conditioners and the Air to Air Heat Exchanger operate together.

If a polar contact such as a photocoupler is used with a no voltage a contact, connect the positive pole to terminal (5), and the negative pole to terminal (1).

Specification of the external contact:  
Contact for microcurrent  
DC12 V 1 mA

## 2) Operating together with a pulse transmission device such as a building management system (separately sold External Input)

- 1) Select "Pulse: ON" for No.1 of SW701 (Changeover switch for pulse / static). (Factory default: "Static")
  - 2) Insert the Remote ON/OFF Adapter NRB-1HE (sold separately) into connector CN705 or CN706. (For the input signal, refer to of "1) When the output signal of the external device is DC12 V or DC24 V (static signal)" or "2) When the output signal of the external device is a no voltage a-contact (static signal)" above.
- \* The pulse width should be 200 msec or more.

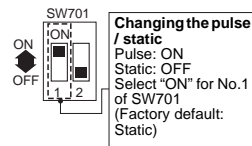

## 3) Switching the remote controller between invalid / valid, low / high, or Bypass mode / Heat exchange mode from an external device (separately sold External Input)

- \* Perform connection with one of the units in the group.
- \* Static signal only

Insert the Remote ON/OFF Adapter NRB-1HE (sold separately) into connector CN705.

- Transmission wire used to extend must be locally procured: Non-polarity, shielded wire (H05 VVC4V5-K or 60227 IEC 74) 0.5 mm<sup>2</sup> Maximum length: 50 m

If a polar contact such as a photocoupler is used with a no voltage a-contact, connect the positive pole to terminal (2), (3), or (4), and the negative pole to terminal (1).

Specification of the external contact:  
Contact for microcurrent  
DC12 V 1 mA

## 1) When switching the remote controller between invalid / valid from an external device

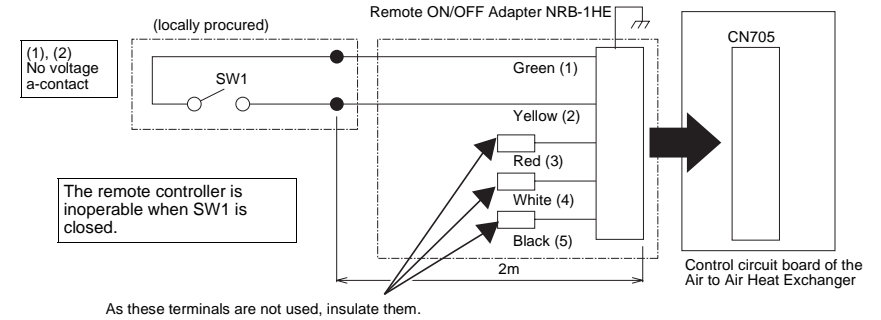

### SW1 [Remote controller Invalid: ON, Valid: OFF]

- For NRC-01HE (remote controller for the Air to Air Heat Exchanger), when one of the buttons below is pressed, blinks and the operation is invalid.
  - \* [ON/OFF] button
  - \* [VENT] button
  - \* [VENT MODE] button
  - \* [VENT FAN] button
- For RBC-AMT32E, AMS41E (remote controller for the air conditioner), pressing the [ON/OFF] button has no effect.
- When the remote controller is inoperable, the 24-hour ventilation mode and nighttime heat purge operation are not available.
- If a command is sent to one of the units in the group, the invalid / valid setting of the remote controller in the group can be switched.

## 2) When switching between low / high from an external device

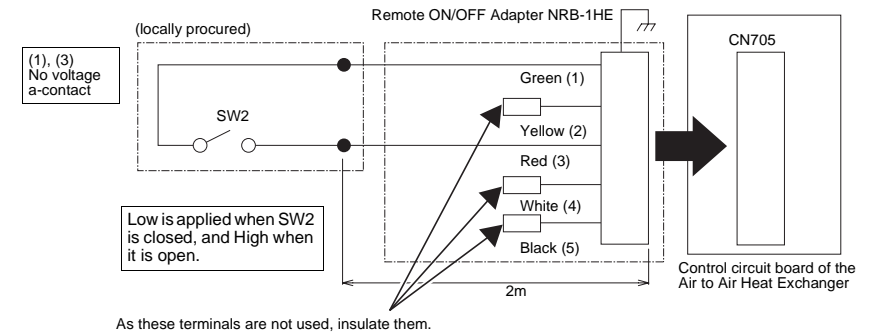

### SW2 [Low: ON, High: OFF]

- For NRC-01HE (remote controller for the Air to Air Heat Exchanger), the message on the display is changed. However, when the air conditioner operates Air to Air Heat Exchanger system linked with air conditioners, ventilation fan speed (Low / High) is changed though the ventilation amount is not shown on the display.
- If a command is sent to one of the units in the group, all the Air to Air Heat Exchangers in the group operate together.
- The latter operation of the remote controller or the external device overrides the former.

**3) When switching between Bypass mode / Heat exchange ventilation from an external device**

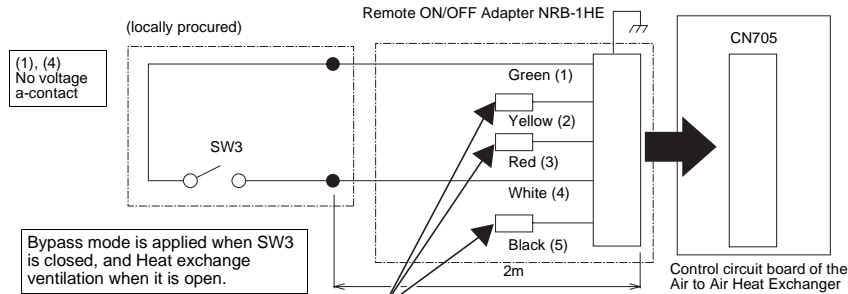

As these terminals are not used, insulate them.

**SW3 [Bypass mode ventilation: ON, Heat exchanging ventilation: OFF]**

- For NRC-01HE (remote controller for the Air to Air Heat Exchanger), the message on the display is changed.
- If a command is sent to one of the units in the group, all the Air to Air Heat Exchangers in the group operate together.
- The latter operation of the remote controller or the external device overrides the former.

**NOTE**

The operation mode will be automatically changed to Heat exchange mode when outdoor air temperature is below 15 °C during Bypass mode. The display remains Bypass mode.

**4 Connecting an auxiliary fan or monitoring operation output (External Output)**

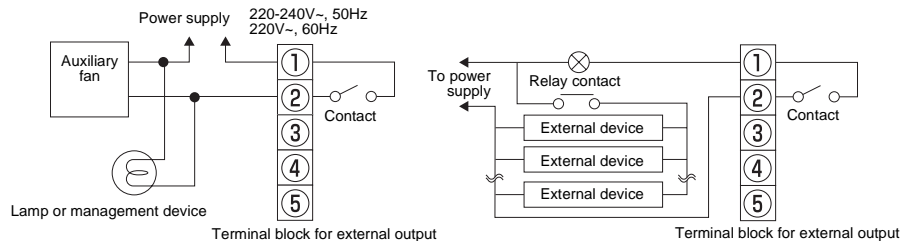

If external devices is used working at a higher voltage and current than the rated values, install a relay according to the diagram above.  
Rated relay: 220-240 VAC

**Connect to the terminal block for external output (1 and 2) in the electrical control box**

**Connection wire (locally procured): 2-core wire (H07 RN-F or 60245 IEC 66) 1.0 mm<sup>2</sup> to 2.5 mm<sup>2</sup>**

<b>Rated contact</b>	
Maximum: 240 VAC, 1 A	24 VDC, 1 A
Minimum: 220 VAC, 100 mA	5 VDC, 100 mA

**Contact is on during normal operation as factory default.**

- Contact is off during 24-hour ventilation mode, nighttime heat purge operation, delay mode or cold mode (temperature is below -10 °C) as factory default.
- The operation output settings can be changed. Refer to "Setting for changing the operation output" on page 22.

**5 Connecting an electric damper (electric shutter) (External Output)**

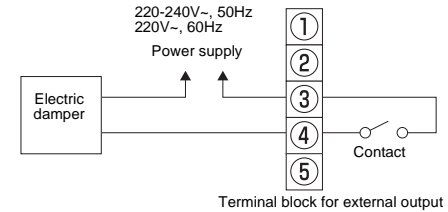

If external output is used working at a higher voltage and current than the rated values, install a relay according to the diagram above (diagram for connecting an auxiliary fan).  
Rated relay: 220-240 VAC

**Connect to the terminal block for external output (3 and 4) in the electrical control box**

**Connection wire (locally procured): 2-core wire (H07 RN-F or 60245 IEC 66) 1.0 mm<sup>2</sup> to 2.5 mm<sup>2</sup>**

**Rated contact (3 to 5: Total value with abnormal signal output)**

Maximum: 240 VAC, 1 A	24 VDC, 1 A
Minimum: 220 VAC, 100 mA	5 VDC, 100 mA

**The electric damper (electric shutter) works during normal operation, 24-hour ventilation mode, and nighttime heat purge operation.**

- The electric damper (electric shutter) also works in the following circumstances:
  - \* While the operation is stopped intermittently in 24-hour ventilation mode
  - \* While the operation is paused during nighttime heat purge operation
  - \* While operating in cold mode (Temperature is below -10 °C.)
- The electric damper (electric shutter) does not work in the following circumstances:
  - \* While the operation is stopped
  - \* Before the monitoring operation of nighttime heat purge operation starts
  - \* While in the delay mode

**6 Monitoring an abnormal signal or the operation signal of bypass mode (External Output)**

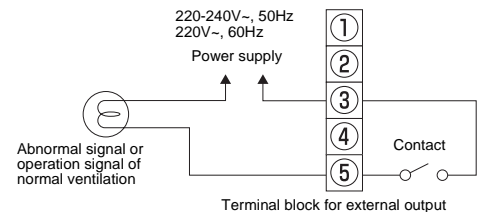

**Connect to the terminal block for external output (3 and 5) in the electrical control box**

**Connection wire (locally procured): 2-core wire (H07 RN-F or 60245 IEC 66) 1.0 mm<sup>2</sup> to 2.5 mm<sup>2</sup>**

**Rated contact (3 and 4: Total value with output of the electric damper)**

Maximum: 240 VAC, 1 A	24 VDC, 1 A
Minimum: 220 VAC, 100 mA	5 VDC, 100 mA

**It is possible to monitor an abnormal signal or the operation signal of bypass mode from the Air to Air Heat Exchanger.**

**Detection of an abnormal signal is possible, as factory default.**

- To change settings so that the operation signal of bypass mode can be detected, refer to "Abnormal signal / bypass mode signal output setting" on page 22.

# 11 Advanced control

## REQUIREMENT

- When the unit is used for the first time, it takes a while for the remote controller to recognize operation input after the power is turned on. This is not a malfunction.
- For details on the auto address setting of air conditioners when operating together with a SMMS series air conditioner (adjust the auto address setting on the circuit board of the outdoor interface), refer to the Installation Manual of the SMMS series air conditioner.
- For details on the auto address setting of air conditioners when operating together with a DI-SDI series air conditioner (the action is performed when the power is turned on), refer to the Installation Manual of the DI-SDI series air conditioner.
- Turn on the Air to Air Heat Exchanger first. Refer to the Installation Manual of the air conditioner about its power supply.

- When shipped from the factory, all the settings are set to [Factory default]. Change the settings of the Air to Air Heat Exchanger if necessary.
- Change settings using the main remote controller (wired remote controller).
- \* The settings cannot be changed using the wireless remote controller, the sub remote controller, or a system without a remote controller (system with only the central remote controller). Therefore, prepare the main remote controller and install it.

## ■ Changing the advanced control settings

### Basic procedure for changing the settings

Change settings while the power is turned off. (Stop operation.)

### ⚠ CAUTION

Do not change any setting codes other than those in this manual; otherwise, the unit may not work or some problems may occur.

### Changing the settings of the Air to Air Heat Exchanger (For NRC-01HE)

- \* For RBC-AMT32E, AMS41E, settings can be changed using the same procedure as NRC-01HE. (Display position is different from that of NRC-01HE.)

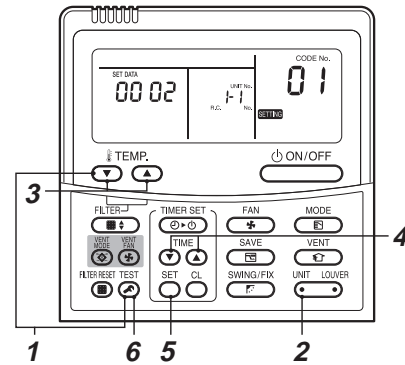

### 1 Push **TEST** button and temp. **▼** button simultaneously for at least 4 seconds.

After a while, the display flashes as shown in the figure.

Confirm that the CODE No. is [01].

- If the CODE No. is not [01], push **TEST** button to erase the display content, and repeat the procedure from the beginning. (No operation of the remote controller is accepted for a while after **TEST** button is pushed.)

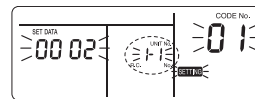

(\* Display content varies with the indoor unit model.)

### 2 Every time the **UNIT LOUVER** button is pressed, the unit numbers of the indoor units or the Air to Air Heat Exchangers in the group are displayed successively. Select the Air to Air Heat Exchanger to change settings. When the unit is selected, the fan starts running to indicate the selected unit.

- \* The unit number of the Air to Air Heat Exchanger is 31-00. 00 represents the indoor unit address specified with No.1 to No.4 of SW702 and No.1 and No.2 of SW703. For NRC-01HE, the **FAN** indicator lights up.

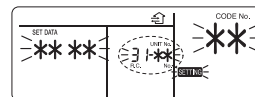

### 3 Using **TEMP.** **▼** / **▲** buttons, specify CODE No. [ \*\* ].

### 4 Using **TIMER time** **▼** / **▲** buttons, select SET DATA [ \*\*\*\* ].

### 5 Push **SET** button. When the display changes from flashing to lit, the setup is completed.

- To change settings of another indoor unit, repeat from Procedure 2.
- To change other settings of the selected indoor unit, repeat from Procedure 3. Use **SET** button to clear the settings. To make settings after **SET** button was pushed, repeat from Procedure 2.

### 6 When settings have been completed, push **TEST** button to determine the settings.

When **TEST** button is pushed, "SETTING" flashes and then the display content disappears and the air conditioner enters the normal stop mode. (While "SETTING" is flashing, no operation of the remote controller is accepted.)

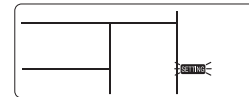

**Codes (DN codes) for changing settings**

Codes in the table below are necessary for local advanced control.

Code	Description	SET DATA and description	Factory default	Note
01	Lighting-up hours of the Filter Sign	0000: None 0001: 150 H 0002: 2500 H 0003: 5000 H 0004: 10000 H	0002: 2500 H	Adjusting this setting is necessary for the header unit.
28	Auto recovery from a power failure	0000: Invalid 0001: Valid * Resumes the status just before the power failure	0000: Invalid	*1
31	Single operation of the fan	0000: Invalid 0001: Valid ON/OFF operation for the Air to Air Heat Exchanger only	0000: Invalid	Adjusting this setting is necessary for the header unit. (System equipped with the Air to Air Heat Exchanger and air conditioners)
48	Imbalanced Fan speed ventilation	0000: Normal 0001: SA (High) > EA (Low) active 0002: SA (Low) < EA (High) active * "High" may be "Extra High".	0000: Normal	Adjusting this setting is necessary for all the Air to Air Heat Exchangers in the group.
49	24-hour ventilation	0001: Invalid 0002: Valid	0001: Invalid	Adjusting this setting is necessary for all the Air to Air Heat Exchangers in the group.
4B	Delayed operation	0000: Invalid 0001-0006: [Setting value] x 10 minutes delay * Delaying the Air to Air Heat Exchanger operation to reduce the air-conditioning load when starting running the air conditioner	0000: Invalid	Adjusting this setting is necessary for all the Air to Air Heat Exchangers in the group. (System equipped with the Air to Air Heat Exchanger and air conditioners)
4C	Nighttime heat purge	0000: Invalid 0001-0048: Start after [Setting value] x 1 hour(s) * Setting for the time before the nighttime heat purge operation starts	0000: Nighttime heat purge OFF	Adjusting this setting is necessary for all the Air to Air Heat Exchangers in the group. (System equipped with the Air to Air Heat Exchanger and air conditioners)
4D	Setting of the exhausting fan operation below -15 °C (OA)	0000: Exhausting fan run 0001: Exhausting fan stop * The supplying fan stops when the temperature is below -15 °C. (OA)	0000: Exhausting fan run	Adjusting this setting is necessary for all the Air to Air Heat Exchangers in the group.
4E	Setting of the linked operation with external devices	0000: ON/OFF linked 0001: ON linked 0002: OFF linked * Specifies whether the ON/OFF operation of the Air to Air Heat Exchanger is linked with the external device operation	0000: ON/OFF linked	Adjusting this setting is necessary for a Air to Air Heat Exchanger to which an adapter for remote ON/OFF control (sold separately) is connected.
EA	Changing the ventilation mode	0001: Bypass mode 0002: Heat Exchange mode 0003: Automatic mode * Compatible with systems without a remote controller and RBC-AMT32E	0003: Automatic mode	*1
EB	Changing the ventilation Fan speed	0002: High 0003: Low 0004: Imbalanced * "High" may be "Extra High". * Compatible with systems without a remote controller and RBC-AMT32E	0002: High	*1

Code	Description	SET DATA and description	Factory default	Note
ED	Changing the operation output	0000: ON during normal operation 0001: ON during normal operation, 24-hour ventilation, or nighttime heat purge operation 0002: ON during 24-hour ventilation or nighttime heat purge operation 0003: ON when SA fan is running 0004: ON when EA fan is running	0000: ON during normal operation	Adjusting this setting is necessary for a Air to Air Heat Exchanger which transfers the operation output.
EE	Changing the abnormal signal / Bypass mode signal output	0000: ON when an abnormal signal is detected 0001: ON when the Bypass mode signal is detected	0000: ON when an abnormal signal is detected	Adjusting this setting is necessary for a Air to Air Heat Exchanger which transfers the operation output.

\* Adjusting this setting is necessary for the header unit when using a system equipped with the Air to Air Heat Exchanger only, and the Air to Air Heat Exchanger with the smallest indoor unit address number when using a system equipped with the Air to Air Heat Exchanger and air conditioners.

**■ Changing the time before the Filter Sign lights up**

The time before the Filter Sign lights up can be changed according to the installation conditions.

\* Adjust this setting for the header unit.

- Select [01] in step 3 on page 19.
- Select a value from the table on the below in step 4 on page 19 according to the preferred time before the Filter Sign lights up.

Code	SET DATA	0000	0001	0002	0003	0004
01	Time before the Filter Sign lights up	None	150 H	2500 H (Factory default)	5000 H	10000 H

**■ Setting of auto recovery from a power failure**

Resumes the status just before the power failure.

\* Adjusting this setting is necessary for the header unit when an Air to Air Heat Exchanger system is used, and the Air to Air Heat Exchanger with the smallest address number when an Air to Air Heat Exchanger system linked with air conditioners is used.

- Select [28] in step 3 on page 19.
- Select [0001] in step 4 on page 19.

Code	SET DATA	0000	0001
28	Auto recovery from a power failure	Invalid (Factory default)	Valid

## Setting of the Air to Air Heat Exchanger single operation (Setting for the header air conditioner)

Single operation of the Air to Air Heat Exchanger is possible when operation of the Air to Air Heat Exchanger is linked with that of the air conditioners.

Use the  button of the wired remote controller.

- \* While the Air to Air Heat Exchanger is in operation,  is displayed on the remote controller.
- \* Adjust this setting for the header air conditioner in the group when an Air to Air Heat Exchanger system linked with air conditioners is used.
- \* This setting is invalid when an Air to Air Heat Exchanger(s) system is used.
  - Select [31] in step 3 on page 19.
  - Select [0001] in step 4 on page 19.

Code	SET DATA	0000	0001
31	Single operation of the fan	Invalid (Factory default)	Valid

### REQUIREMENT

Do not change this setting when the operation is linked by a signal from an external device or remotely controlled on and off (page 16) by using Remote ON/OFF Adapter NRB-1HE (sold separately).

## Setting of the imbalanced ventilation Fan speed

SA / EA imbalanced operation of the Air to Air Heat Exchanger is possible.

Use the  button of the remote controller.

- \* Adjust this setting for all the Air to Air Heat Exchangers when group operation is applied.
- \* Though RBC-AMT32E, RBC-AMS41E cannot be used, this setting can still be changed. For details, refer to "Ventilation Fan speed setting" on page 22.
  - Select [48] in step 3 on page 19.
  - Select [0001: SA (High) > EA (Low) active] or [0002: SA (Low) < EA (High) active] in step 4 on page 19.

Code	SET DATA	0000	0001	0002
48	Imbalanced ventilation Fan speed	Invalid (Factory default)	SA (High) > EA (Low) active	SA (Low) < EA (High) active

## Setting of 24-hour ventilation

24-hour ventilation (intermittent operation of Low mode) is possible.

- \* Adjust this setting for all the Air to Air Heat Exchangers in the group.
- \* The air volume of ventilation is half as much as that of Low mode (Ventilated at 60-minute intervals)
- \* When 24-hour ventilation is in operation, the 24-hour ventilation indicator is not displayed on RBC-AMT32E, RBC-AMS41E.
  - Select [49] in step 3 on page 19.
  - Select [0001] in step 4 on page 19.

Code	SET DATA	0000	0001
49	24-hour ventilation	Invalid (Factory default)	Valid

## Setting of delayed operation (Delayed operation of the Air to Air Heat Exchanger when it operates link with air conditioners)

The operation of the Air to Air Heat Exchanger is delayed by [Setting value] x 10 minutes (10 to 60 minutes) when the [ON/OFF] button is pressed. (Available when the operation of the Air to Air Heat Exchanger is linked with that of air conditioners)

- \* Adjust this setting for all the Air to Air Heat Exchangers in the group. (only when the Air to Air Heat Exchanger(s) operates together with air conditioners)
- \* This setting is invalid for a system equipped with the Air to Air Heat Exchanger only.
- \* For NRC-01HE, the  indicator lights up.
  - Select [4B] in step 3 on page 19.
  - Select a value from the table on the below in step 4 on page 19 according to the preferred time.

Code	SET DATA	0000	0001 to 0006
4B	Delayed operation	Invalid (Factory default)	[Setting value] x 10 minutes delay

## Nighttime heat purge setting

Nighttime heat purge exhausts hot air in the room by bypass mode and reduces the cooling load in the morning. Monitoring operation starts after [Setting value] x 1 hour(s). (1 to 48 hours)

- \* Adjust this setting for all the Air to Air Heat Exchangers in the group. (Only when the Air to Air Heat Exchanger(s) operates link with air conditioners)
- \* This setting is invalid for an Air to Air Heat Exchanger system.
  - Select [4C] in step 3 on page 19.
  - Select a value from the table on the below in step 4 on page 19 according to the preferred time.

Code	SET DATA	0000	0001 to 0048
4C	Nighttime heat purge	0000: Invalid (Factory default)	Start after [Setting value] x 1 hour(s)

## Setting for operation of the exhausting fan below -15 °C

Stops the exhausting fan when the temperature outside falls below -15 °C

- \* Adjust this setting for all the Air to Air Heat Exchangers in the group.
- \* The air supplying fan stops regardless of this setting.
- \* When the indoor temperature is over 26 °C, the exhausting fan stops even when the outdoor temperature is higher than -15 °C.
  - Select [4D] in step 3 on page 19.
  - Select [0001] in step 4 on page 19.

Code	SET DATA	0000	0001
4D	Exhausting fan operation below -15 °C	Exhausting fan runs (Factory default)	Exhausting fan stops

## ■ Setting for linked operation with external devices

Specifies the operation of the Air to Air Heat Exchanger linked with the on/off operation of external devices

\* For group operation, adjust this setting for the Air to Air Heat Exchanger to which the Remote ON/OFF Adapter (NRB-1HE: sold separately) is connected.

- Select [4E] in step 3 on page 19.
- Select a value from the table on the below in step 4 on page 19.

Code	SET DATA	0000	0001	0002
4E	Linked operation with external devices	ON/OFF linked (Factory default)	ON linked	OFF linked

0000: The Air to Air Heat Exchanger starts / stops together with the starting / stopping of an external device. (The latter operation of the remote controller or the switch of the external device overrides the former.)  
 0001: The Air to Air Heat Exchanger starts together with the starting of an external device. Use the remote controller to stop operation.  
 0002: The Air to Air Heat Exchanger stops together with the stopping of an external device. Use the remote controller to start operation.

## ■ Ventilation mode setting

The setting of the ventilation mode can be changed when the remote controller for air conditioners (RBC-AMT32E, RBC-AMS41E) or a system without a remote controller is used.

- \* Adjusting this setting is necessary for the header unit when an Air to Air Heat Exchanger system is used (RBC-AMT32E can not be used.), and for the Air to Air Heat Exchanger with the smallest address number when an Air to Air Heat Exchanger system linked with air conditioners is used.
- \* When the remote controller NRC-01HE is installed, this setting is invalid. (The remote controller can be used for operation.)
  - Select [EA] in step 3 on page 19.
  - Select a value from the table on the below in step 4 on page 19.

Code	SET DATA	0000	0001	0002
EA	Changing the ventilation mode	Bypass mode	Heat Exchange mode	Automatic mode (Factory default)

## ■ Ventilation Fan speed setting

The setting of the ventilation Fan speed can be changed when the remote controller for air conditioners (RBC-AMT32E, RBC-AMS41E) or the system without the remote controller is used.

- \* Adjusting this setting is necessary for the header unit when an Air to Air Heat Exchanger system is used (RBC-AMT32E can not be used.), and for the Air to Air Heat Exchanger with the smallest address number when an Air to Air Heat Exchanger system linked with air conditioners is used.
- \* When the remote controller NRC-01HE is installed, this setting is invalid. (The remote controller can be used for operation.)
  - Select [EB] in step 3 on page 19.
  - Select a value from the table on the below in step 4 on page 19.

Code	SET DATA	0002	0003	0004
EB	Changing the ventilation amount	High (Factory default)	Low	Imbalanced

- \* When [0004] is selected, adjust setting of the imbalanced ventilation Fan speed (Code: 48).

## ■ Setting for changing the operation output

Terminals 1 and 2 for external devices can be used to connect an auxiliary fan or to use the operation output for operating external devices connected to the terminal. It can be specified when the operation output is used.

\* Apply this setting for the Air to Air Heat Exchanger to which an external device is connected.

- Select [ED] in step 3.
- Select a value from the table below in step 4.

Code	SET DATA	0000	0001	0002	0003	0004
ED	Changing the operation output	ON during normal operation (Factory default)	ON during normal operation, 24-hour ventilation, or nighttime heat purge operation	ON during 24-hour ventilation or nighttime heat purge operation	ON when SA fan is running	ON when EA fan is running

0000: Contact is on only during normal operation.  
 \* Contact is off during 24-hour ventilation or nighttime heat purge operation.  
 \* Contact is off during cold mode (while the temperature is below -10 °C).  
 0001: Contact is on during normal operation, 24-hour ventilation, or nighttime heat purge operation.  
 \* Contact is on when 24-hour ventilation is stopped intermittently.  
 \* Contact is off when nighttime heat purge operation is on standby. (paused before the monitoring operation of the nighttime heat purge operation starts)  
 \* Contact is off during cold mode (while the temperature is below -10 °C).  
 0002: Contact is on during 24-hour ventilation or nighttime heat purge operation.  
 \* Contact is on when 24-hour ventilation is stopped intermittently.  
 \* Contact is off during normal operation or when the nighttime heat purge operation is on standby. (paused before the monitoring operation of the nighttime heat purge operation starts)  
 \* Contact is off during cold mode (while the temperature is below -10 °C).  
 0003: Contact is on only when SA fan is running.  
 \* Contact is off when 24-hour ventilation is stopped intermittently, so do not connect an auxiliary fan.  
 0004: Contact is on only when EA fan is running.  
 \* Contact is off when 24-hour ventilation is stopped intermittently, so do not connect an auxiliary fan.

- \* Contact is off during delayed operation, when switching the damper (Heat exchange mode / Bypass mode), regardless of the selected value.

## ■ Abnormal signal / bypass mode signal output setting

Terminals 3 to 5 for external output can be used to detect an abnormal signal / bypass mode signal output. Output signal to be detected can be selected.

- \* Adjust this setting for the Air to Air Heat Exchanger to which an external output is connected.
- \* When [0000] is selected, contact is on if there is any error on the connected Air to Air Heat Exchanger.
  - Select [EE] in step 3 on page 19.
  - Select a value from the table on the below in step 4 on page 19.

Code	SET DATA	0000	0001
EE	Changing the abnormal signal / bypass mode signal output	ON when an abnormal signal is detected (Factory default)	ON when the bypass mode signal is detected

0000: Contact is on when an abnormal signal output is detected.  
 0001: Contact is on when the bypass mode signal output is detected.  
 \* Contact is on during nighttime heat purge operation.  
 \* Contact is off when the nighttime heat purge operation is on standby. (paused before the monitoring operation of the nighttime heat purge operation starts)  
 \* Even when  is displayed on the remote controller, contact is off during the Heat exchange mode.

## Remote controller switch monitoring function

This function is available to call the service monitor mode from the remote controller during a test run to acquire temperatures of sensors of indoor unit (Air to Air Heat Exchanger).

- 1 Push **ON** and **TEST** buttons simultaneously for at least 4 seconds to call the service monitor mode.
- 2 Pushing **TEMP.** buttons, select the number of sensor (CODE No.) to be monitored. (See the following table.)
- 3 Pushing **UNIT LOWER** (left side of the button), select an indoor unit to be monitored.  
\* The unit number of the Air to Air Heat Exchanger is 31-00.
- 4 Push **TEST** button to return to the normal display.

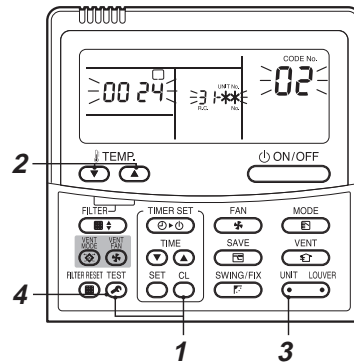

Indoor unit data (Air to Air Heat Exchanger)	
CODE No.	Data name
02	Indoor unit Return air temperature (TRA)
F0	Microcomputer cumulative energized hours (x 100h)
F2	Supply air fan cumulative energized hours (x 100h)
F3	Filter cumulative hours (x1 h)
FA	Indoor unit outdoor air temperature (TOA)

# 12 Test run

## Before performing a test run

- Before turning on the power supply, carry out the following procedure.  
Using 500 V-megger, check that resistance of 1 MΩ or more exists between the terminal block of the power supply and the earth (earthing).  
If resistance of less than 1 MΩ is detected, do not run the unit.
- When a test run is performed together with air conditioners, follow the Installation Manuals of the air conditioners.

## Performing a test run of the Air to Air Heat Exchanger using the remote controller (NRC-01HE)

Confirm that the unit operates properly referring to the Owner's Manual of the Air to Air Heat Exchanger.

Operation item	Button	Display	Operation
1. Starting operation			The operation lamp lights up, then the Air to Air Heat Exchanger starts running.
2. Changing the ventilation mode			Each time the ventilation mode button is pressed, the mode changes as follows: →  →
3. Changing the ventilation amount			Each time the ventilation amount button is pressed, the ventilation amount changes as follows: → *  or  is displayed only when the imbalanced ventilation Fan speed is valid.
4. Stopping operation			The operation lamp goes off, then the Air to Air Heat Exchanger stops running.



# 13 Maintenance

Running the Air to Air Heat Exchanger for a long period causes the filter or heat exchange element to become clogged with dust. If the filter or heat exchange element is clogged, the ventilation amount is reduced and ventilation effect will be deteriorated. Clean the filter and heat exchange element regularly according to the extent of dust accumulation.

## WARNING

Before performing maintenance, stop the unit, then turn off the breaker.

- Otherwise, an electric shock or injury may result. Do not pour or spray water or detergent on the electric parts.
- Otherwise, an electrical leakage may occur and a fire or electric shock may result.

## CAUTION

Wear protective gloves when performing maintenance.

- Otherwise, an injury may result.

## Maintenance of the filter and heat exchange element

### Filter maintenance (Clean the filter once or twice a year.)

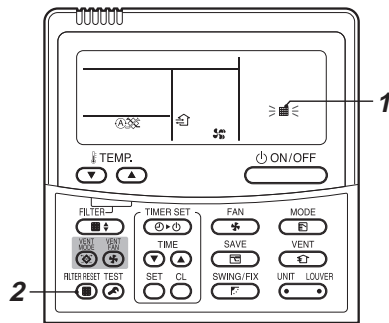

- 1 Clean the filter if is indicated on the remote controller.
- 2 Press the button after cleaning the filter. The indicator disappears.

### 1 Open the inspection cover.

Enter the ceiling cavity remove the screw of fixed part of Inspection cover and remove the fixing lever (support the inspection cover while removing the brackets), then open the inspection cover.

#### ▼ VN-M150 to 1000HE

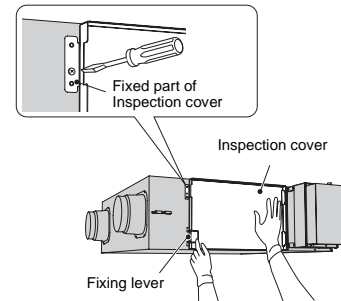

#### ▼ VN-M1500 and 2000HE

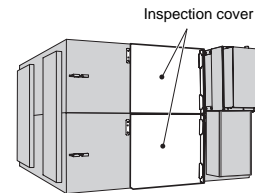

### 2 Pull out the heat exchange elements.

Filters are attached to the heat exchange element. Hold the handle of the heat exchange element, then pull it out.

- \* 2 heat exchange elements are equipped with this unit. (VN-M150 to 1000HE)
- \* 4 heat exchange elements are equipped with this unit. (VN-M1500 and 2000HE)

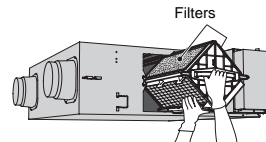

## CAUTION

The table below shows the weight of each heat exchange element. Handle the heat exchange element carefully so as not to drop it.

Model name	Weight (kg/unit)	Quantity
VN-M150HE	1.7	2
VN-M250HE	1.7	2
VN-M350HE	1.7	2
VN-M500HE	2.9	2
VN-M650HE	2.9	2
VN-M800HE	3.7	2
VN-M1000HE	3.7	2
VN-M1500HE	3.7	4
VN-M2000HE	3.7	4

### 3 Remove the filters.

Remove the filters from the frame of the heat exchange element.

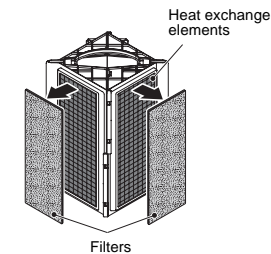

### 4 Clean the filters.

Clean the filters by dusting them or using a vacuum cleaner. If the filters are badly clogged, wash them by pressing them down in lukewarm water with a neutral dish washing liquid.

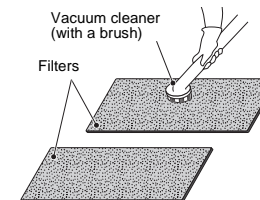

## NOTE

- Do not dry the filter with heat from a flame; otherwise, deformation or deterioration of the filter may result.
- Light-up hours of the indicator is set to [2500 H]. If the filter is badly clogged, change the setting value. For the details, refer to the "Changing the time before the Filter Sign lights up" on page 20.
- Do not soak the filter in water hotter than 60°C; otherwise, deformation or deterioration of the filter may result.

## Maintenance of the heat exchange elements (Clean the heat exchange elements once or twice in 2 years.)

### 1 Clean the heat exchange elements

Remove the dust on the surface of the heat exchange element using a vacuum cleaner.

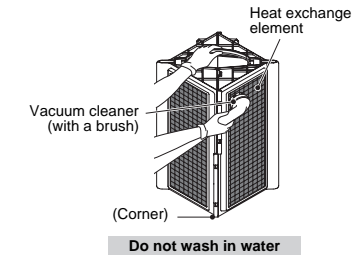

## NOTE

- Use a vacuum cleaner with a brush, and stroke the brush gently on the heat exchange element.
- Do not press the nozzle of the vacuum cleaner hard against the heat exchange element; otherwise, the surface of it will be scratched.
- Do not wash the heat exchange element in water.

\* Contact the dealer or installer when the heat exchange element is damaged and replacing it is necessary.

## ■ Reinstallation after maintenance

### 1 Attach the filters.

Attach the filters after they have completely dried. Attach them to the frame of the heat exchange element as before.

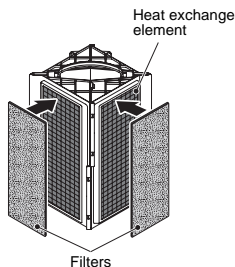

### 2 Attach the heat exchange elements.

Install the heat exchange elements as before.

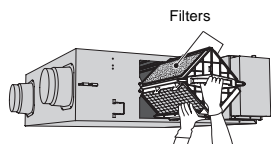

#### NOTE

Attach the filters. If this unit is used without them, the heat exchange elements will become clogged and a breakdown may result.

### 3 Attach the inspection cover.

Fit the fixing lever to the inspection cover to attach it securely and fix the fixed part of inspection cover with a screw.

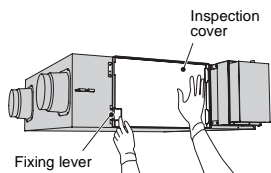

# 14 Troubleshooting

## ■ Confirmation and check

When an error occurred in the Air to Air Heat Exchanger, the check code and the unit No. of Air to Air Heat Exchanger appear on the display part of the remote controller.

The check code is only displayed during the operation. If the display disappears, operate the Air to Air Heat Exchanger according to the following "Confirmation of error history" for confirmation.

\* Unit No. of Air to Air Heat Exchanger is 31-00.

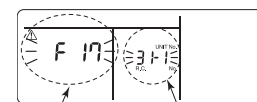

Check code

Unit No. of the Air to Air Heat Exchanger with a problem

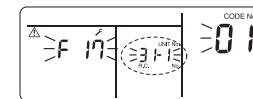

### 2 Every pushing of **TEMP.** button used to set temperature, the error history stored in memory is displayed in order.

The numbers in CODE No. indicate CODE No. [01] (latest) → [04] (oldest).

#### REQUIREMENT

Do not push **CL** button because all the error history of the Air to Air Heat Exchanger will be deleted.

### 3 After confirmation, push **TEST** button to return to the usual display.

## ■ Confirmation of error history

When an error occurred on the Air to Air Heat Exchanger, the error history can be confirmed with the following procedure. (The error history is stored in memory up to 4 troubles.)

The error can be confirmed from both operating status and stop status.

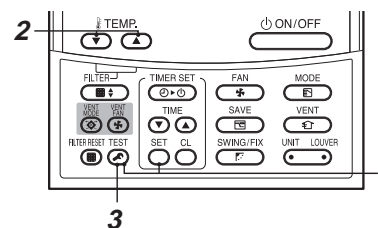

### 1 When pushing **SET** and **TEST** buttons at the same time for 4 seconds or more, the following display appears.

If [Service check] **⚠** is displayed, the mode enters in the trouble history mode.

- [01: Order of error history] is displayed in CODE No. window.
- [Check code] is displayed in CHECK window.
- [Air to Air Heat Exchanger address in which an error occurred] is displayed in Unit No.

\* Unit No. of Air to Air Heat Exchanger is 31-00.

## ■ Check codes and parts to be checked

Wired remote controller display	Main defective parts	Judging device	Parts to be checked / error description
E01	No header remote controller	Remote controller	Incorrect remote controller setting --- The header remote controller has not been set (including two remote controllers).
	Remote controller communication error		No signal can be received from the indoor unit.
E02	Remote controller transmission error	Remote controller	System interconnection wires, indoor P.C. board, remote controller --- No signal can be sent to the indoor unit.
E03	Indoor unit-remote controller regular communication error	Indoor	Remote controller, network adapter, indoor P.C. board --- No data is received from the remote controller or network adapter.
E08	Duplicated indoor addresses	Indoor	Indoor address setting error --- The same address as the self-address was detected.
E09	Duplicated header remote controllers	Remote controller	Remote controller address setting error --- Two remote controllers are set as header in the double-remote controller control.
			(* The header indoor unit stops raising alarm and follower indoor units continue to operate.)
E18	Header indoor unit-indoor follower unit regular communication error	Indoor	Indoor P.C. board --- Regular communication is not possible between header and follower indoor units or between twin header (main) and follower (sub) units.
F17	Air to Air Heat Exchanger (TOA) error	Air to Air Heat Exchanger	Outdoor Air sensor (TOA), indoor P.C. board --- Open-circuit or short-circuit of the heat exchanger sensor (TOA) was detected.
F18	Air to Air Heat Exchanger (TRA) error	Air to Air Heat Exchanger	Return Air sensor (TRA), indoor P.C. board --- Open-circuit or short-circuit of the heat exchanger sensor (TRA) was detected.
F29	Indoor unit, other P.C. board error	Indoor	Indoor P.C. board --- EEPROM error
L03	Duplicated header indoor units	Indoor	Indoor address setting error --- There are two or more header units in the group.
L08	Indoor group address not set	Indoor	Indoor address setting error --- Indoor address group has not been set.
L09	Indoor power level not set	Indoor	Indoor power level has not been set.
L20	LAN communication error	Indoor	Address setting, central control remote controller, network adapter --- Duplication of address in central control communication
P31	Other indoor unit error	Indoor	Another indoor unit in the group is raising an alarm.
			E03/L07/L03/L08 alarm check locations and error description

\* "Indoor" in "Judging device" refers to the Air to Air Heat Exchanger or the air conditioner.

**TOSHIBA CARRIER CORPORATION**  
336 TADEHARA, FUJI-SHI, SHIZUOKA-KEN 416-8521 JAPAN