



Compact High-wall Type

Slim-line design

This compact high-wall is perfect for limited spaces, such as offices, small shops or hotel rooms.

The unit is compact (only 275x790x208mm) and light - weight (11kgr).

Clean unit: the panel is easily detachable for fast grille and filters cleaning.

Auto - swing mechanism.



Remote controller

MMK-AP*4H**

MMK-AP0074H to AP0124H

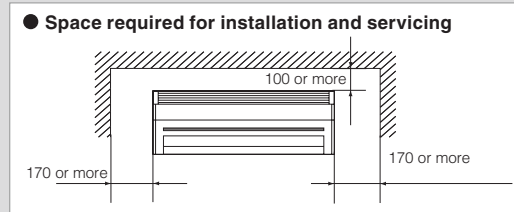
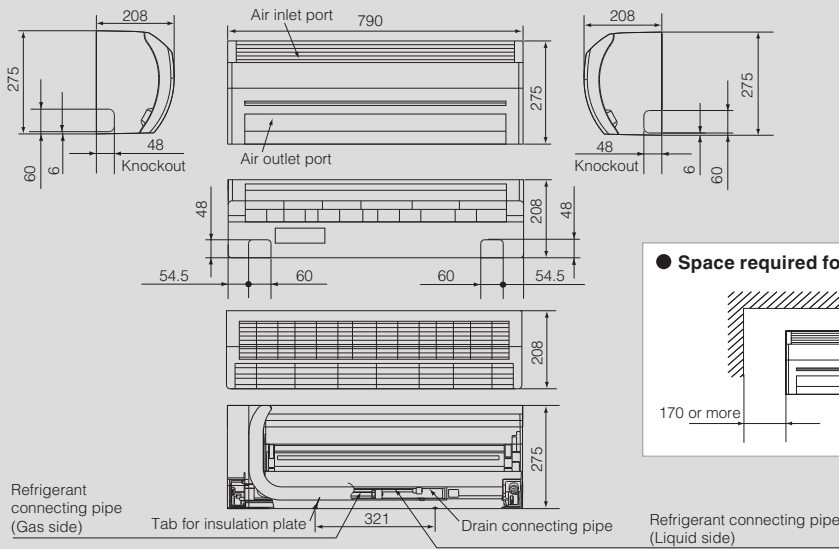

(Unit: mm)

Technical specifications

Model name	MMK-	AP0074MH-E	AP0094MH-E	AP0124MH-E
Cooling/Heating capacity*1	(kW)	2.2/2.5	2.8/3.2	3.6/4.0
Electrical characteristics	Power requirements	1-phase 50 Hz 230 V (220-240 V) (Power exclusive for indoor is required.)		
	Power consumption 50 Hz	(kW)	0.017	0.018
External dimensions	Height	(mm)	275	
	Width	(mm)	790	
	Depth	(mm)	208	
Total weight	(kg)	11		
Fan unit	Standard air flow (High/Mid/Low)	(m ³ /h)	480/420/360	510/450/360
	Motor output	(W)	30	
Connecting pipe	Gas side	(mm)	ø9.5	
	Liquid side	(mm)	ø6.4	
	Drain port (nominal dia.)		16 (polyvinyl chloride tube)	
Sound pressure level*2 (High/Mid/Low)	(dB(A))	35/32/29	36/33/29	37/33/29

*1 This reference piping consists of 5 m of main piping and 2.5 m of branch piping connected at the same height level.

*2 The actual values in an external operating environment are generally higher than the indicated values due to the contribution from ambient noise.